



# **FORKARDT HARDINGE**



## **HCAC Collet Adaptation Chucks**

# HCAC Collet Adaptation Chucks

*Why would I want to use collets on my jaw-chuck lathe?*

## To Increase Productivity over 3-Jaw Chucks

- Faster job changeover using collets—5C, 16C, 3J, 22J, 35J, S15, S20, S26, S30, #11 B&S, #21 B&S, #22 B&S, B42, B60, B65, DIN 90 and many more
- Higher spindle speeds for reduced cycle times

## To Increase Capability over 3-Jaw Chucks

- More work envelope to machine longer workpieces
- Achieve higher precision
- Interchangeable Style "S" master pads accommodate a wide range of workpiece sizes and configurations

## To Increase Control over 3-Jaw Chucks

- Exact part length control
- Improved concentricity for optimum part roundness

Additionally, centrifugal force is not an issue with Collet Adaptation Chucks. Your machine can operate at the maximum rpm your tooling will allow. Higher rpm means more pieces per hour and higher profits. Review our brochure and select the HCAC Collet Adaptation Chuck that best meets your requirements.

**Link-ups** can be designed to fit your specific machine. The same link-up can then be used for the entire line of workholding elements including internal Sure-Grip® Collet applications. Please fill in the "Link-up Information" form on page 27 and then contact us.

**Custom-manufacturing** available...call 800-843-8801.

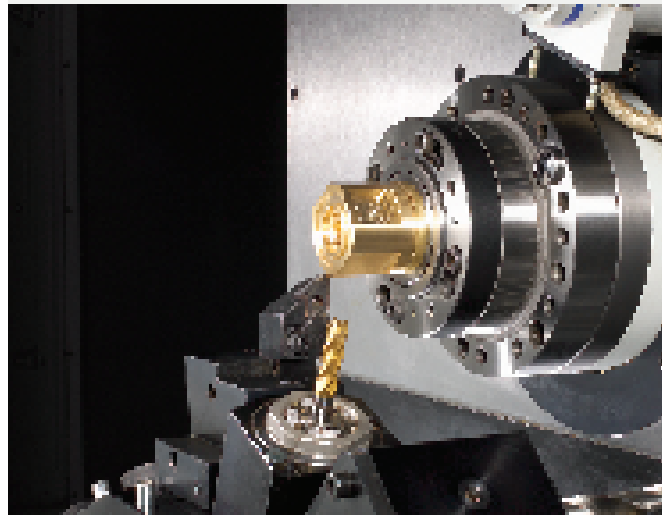

Cover Photo: B42 Collet application on a Hardinge QUEST® LMC42 Lean Manufacturing Center

## Table of Contents

Collet Adaptation Chucks for CNC Machines	
Plain Nose .....	3-4
Stepped Nose .....	3-4
Style "S" Masters .....	5
Spindle-to-Spindle .....	6
Style "B" Stationary Dead-Length .....	7
Dead-Length .....	8
Collet Adaptation Chucks for Hardinge CNC Machines	
Hardinge TALENT®, GS- / SV-series Turning Centers .....	9-10
Hardinge QUEST Twin Turn® 65 Turning Center .....	11-13
All Hardinge 16C Spindle Machines.....	14
Hardinge QUEST GT27SP Gang-Tool CNC Lathe.....	14
Machine Tool Builders' Cross Reference.....	15-19
Collet Adaptation Chucks for Manual Machines	
Dead-Length® Scroll-Style.....	20
Sjogren .....	21-25
Threaded-Nose 2¼"-8 TPI Speed Chucks.....	22
American Standard (ANSI) Speed Chucks .....	22
Cam-Lock Speed Chucks.....	23
Plain-Back Speed Chucks.....	24
Taper-Key Speed Chucks.....	25
FlexC™ Collet Chucks.....	26
Custom-Manufacturing .....	26
Spindle Draw Bar Adapter (Link-up) Information .....	27

# Plain and Stepped Nose - Dimensions

## Collet Adaptation Chucks for CNC Lathes

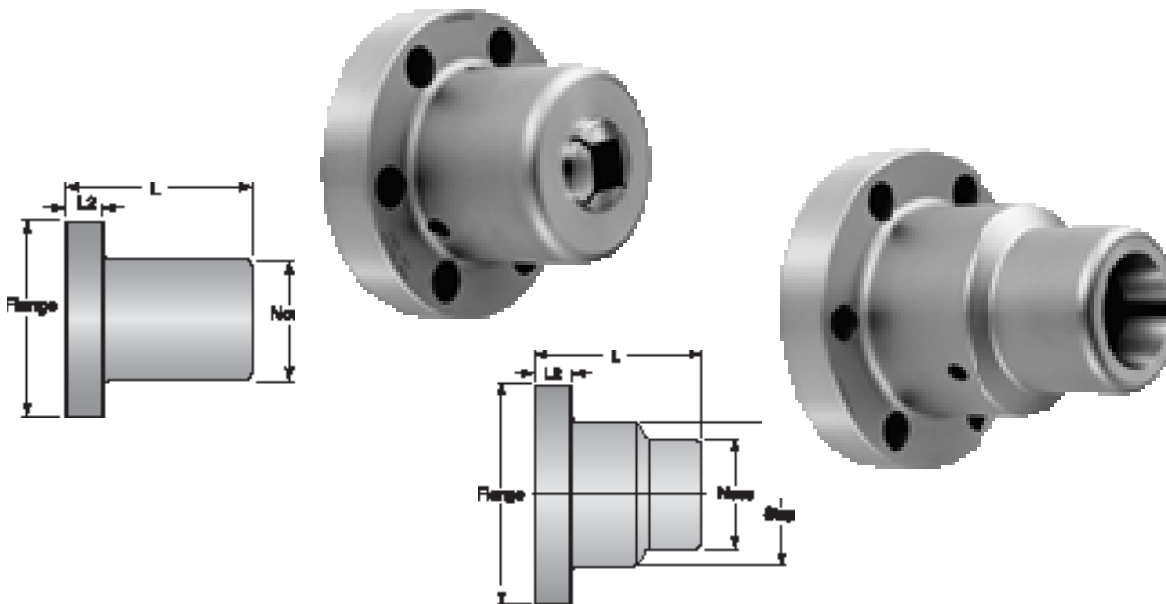

### Collet Adaptation Chucks Plain and Stepped - Dimensions

Spindle-to-Collet	Assembly Part Number	Spindle	Length L	Length L2	Flange OD	Step OD	Nose OD	Collet Thru-Capacity
A2-4 5C	97Z00-00-90-7176N	A2-4	3.500" (88.90)	0.937" (23.80)	4.250" (107.95)	—	2.500" (63.50)	1.0625" (26.98)
A2-5 5C-35	7801-00-00-000000	A2-5	3.500" (88.90)	1.000" (25.40)	5.250" (133.35)	—	3.250" (82.55)	1.0625" (26.98)
A2-5 5C-50	7803-00-00-000000	A2-5	5.000" (127.00)	1.000" (25.40)	5.250" (133.35)	—	3.250" (82.55)	1.0625" (26.98)
A2-5 5C-50	7803-00-00-645000	A2-5	5.000" (127.00)	1.000" (25.40)	5.250" (133.35)	—	3.250" (82.55)	1.0625" (26.98)
A2-5 16C-60	7817-00-00-000000	A2-5	6.000" (152.40)	1.000" (25.40)	5.250" (133.35)	—	3.250" (82.55)	1.625" (41.27)
A2-5 16C-60	7817-00-00-645000	A2-5	6.000" (152.40)	1.000" (25.40)	5.250" (133.35)	—	3.250" (82.55)	1.625" (41.27)
A2-5 3J-55	7811-00-00-000000	A2-5	5.500" (139.70)	1.000" (25.40)	5.250" (133.35)	—	3.250" (82.55)	1.750" (44.45)
A2-5 3J-55	7811-00-00-645000	A2-5	5.500" (139.70)	1.000" (25.40)	5.250" (133.35)	—	3.250" (82.55)	1.750" (44.45)
A2-6 5C-50	7805-00-00-000000	A2-6	5.000" (127.00)	1.125" (28.57)	6.500" (165.10)	4.250" (107.95)	3.250" (82.55)	1.0625" (26.98)
A2-6 5C-50	7805-00-00-852000	A2-6	5.000" (127.00)	1.125" (28.57)	6.500" (165.10)	4.250" (107.95)	3.250" (82.55)	1.0625" (26.98)
A2-6 5C-50	7805-00-00-866000	A2-6	5.000" (127.00)	1.125" (28.57)	6.500" (165.10)	4.250" (107.95)	3.250" (82.55)	1.0625" (26.98)
A2-6 5C-60	7807-00-00-000000	A2-6	6.000" (152.40)	1.125" (28.57)	6.500" (165.10)	4.250" (107.95)	3.250" (82.55)	1.0625" (26.98)
A2-6 16C*	97Z00-00-90-5659P	A2-6	4.750" (120.65)	1.125" (28.57)	6.500" (165.10)	4.250" (107.95)	3.250" (82.55)	1.625" (41.27)
A2-6 16C-60	7819-00-00-000000	A2-6	6.000" (152.40)	1.125" (28.57)	6.500" (165.10)	4.250" (107.95)	3.250" (82.55)	1.625" (41.27)
A2-6 16C-60	7819-00-00-852000	A2-6	6.000" (152.40)	1.125" (28.57)	6.500" (165.10)	4.250" (107.95)	3.250" (82.55)	1.625" (41.27)
A2-6 16C-60	7819-00-00-866000	A2-6	6.000" (152.40)	1.125" (28.57)	6.500" (165.10)	4.250" (107.95)	3.250" (82.55)	1.625" (41.27)
A2-6 3J-60	7813-00-00-000000	A2-6	6.000" (152.40)	1.125" (28.57)	6.500" (165.10)	4.250" (107.95)	3.250" (82.55)	1.750" (44.45)
A2-6 3J-60	7813-00-00-852200	A2-6	6.000" (152.40)	1.125" (28.57)	6.500" (165.10)	4.250" (107.95)	3.250" (82.55)	1.750" (44.45)
A2-6 3J-60	7813-00-00-866000	A2-6	6.000" (152.40)	1.125" (28.57)	6.500" (165.10)	4.250" (107.95)	3.250" (82.55)	1.750" (44.45)
A2-6 20C	97Z00-00-90-8289M	A2-6	8.000" (203.20)	1.125" (28.57)	6.500" (165.10)	—	4.250" (107.95)	2.000" (50.80)
A2-6 20C	7820-00-00-852000	A2-6	8.375" (212.72)	1.125" (28.57)	6.500" (165.10)	—	4.340" (110.23)	2.000" (50.80)
A2-8 16C	97Z00-00-90-4853M	A2-8	6.500" (165.10)	1.250" (31.75)	8.250" (209.55)	5.500" (139.70)	3.250" (82.55)	1.625" (41.27)
A2-8 3J-60	7815-00-00-000000	A2-8	6.000" (152.40)	1.250" (31.75)	8.250" (209.55)	5.500" (139.70)	3.250" (82.55)	1.750" (44.45)
A2-8 20C	97Z00-00-90-5693P	A2-8	5.834" (148.18)	1.750" (44.45)	8.250" (209.55)	—	4.280" (108.71)	2.000" (50.80)
A2-8 20C	97Z00-00-90-8340N	A2-8	8.000" (203.20)	1.250" (31.75)	8.250" (209.55)	—	5.500" (139.70)	2.000" (50.80)
A2-8 25C	97Z00-00-90-6395N	A2-8	7.450" (189.23)	1.250" (31.75)	8.250" (209.55)	5.500" (139.70)	4.700" (119.38)	2.559" (64.99)

Note: A link-up adapter is required for these chucks. Fill in the data sheet on page 27 and call Hardinge for a quotation.  
 Collet Chucks for Hardinge Talent® CNC Lathes include a preconfigured link-up adapter.  
 \* For sub-spindle application.

(Millimeters in Parentheses)

# Plain and Stepped Nose - Parts List

## Collet Adaptation Chucks for CNC Lathes

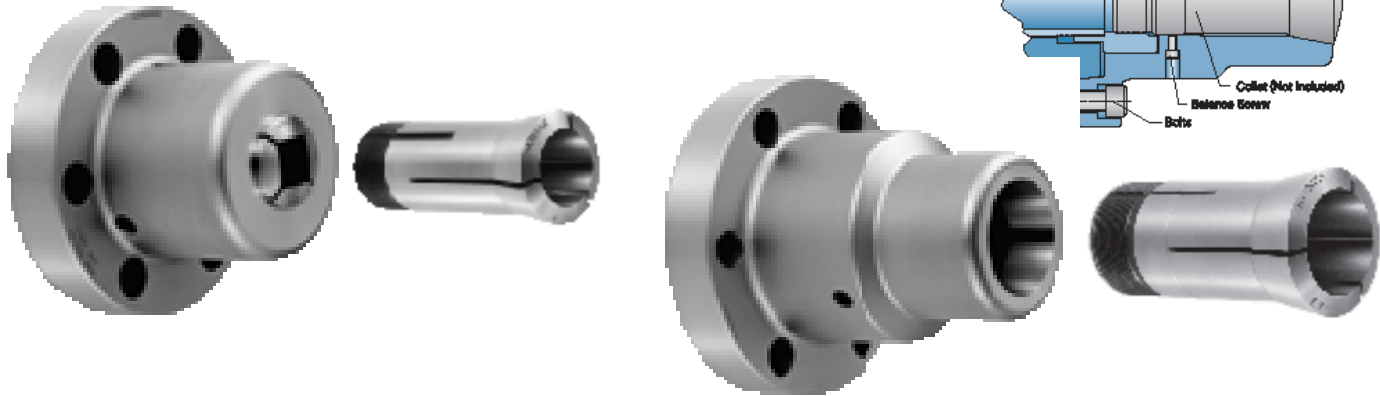

### Collet Adaptation Chucks Plain and Stepped - Parts List (Collets sold separately)

Spindle-to-Collet	Assembly Part Number	Adapter Body	Link-Up Adapter	Collet Key	Balance Screw (Key Blank)	Inch Bolts	Metric Bolts
A2-4 5C	97Z00-00-90-7176N	97Z00-00-90-7177N	OA	7801-00-00-000002	7801-00-00-000003	—	MS-0104019
A2-5 5C-35	7801-00-00-000000	7801-00-00-000001	OA	7801-00-00-000002	7801-00-00-000003	0101216	MS-0104019
A2-5 5C-50	7803-00-00-000000	7803-00-00-000001	OA	7801-00-00-000002	7801-00-00-000003	0101216	MS-0104019
A2-5 5C-50	7803-00-00-645000	7803-00-00-000001	7803-00-90-645000	7801-00-00-000002	7801-00-00-000003	0101216	MS-0104019
A2-5 16C-60	7817-00-00-000000	7817-00-00-000001	OA	7801-00-00-000002	7801-00-00-000003	0101216	MS-0104019
A2-5 16C-60	7817-00-00-645000	7817-00-00-645001	7833-00-90-645000	7801-00-00-000002	7801-00-00-000003	0101216	MS-0104019
A2-5 3J-55	7811-00-00-000000	7811-00-00-000001	OA	7811-00-00-000002	7801-00-00-000003	0101216	MS-0104019
A2-5 3J-55	7811-00-00-645000	7811-00-00-000001	7811-00-90-645000	7811-00-00-000002	7801-00-00-000003	0101216	MS-0104019
A2-6 5C-50	7805-00-00-000000	7805-00-00-000001	OA	7801-00-00-000002	7801-00-00-000003	0101420	MS-0104220
A2-6 5C-50	7805-00-00-852000	7805-00-00-000001	7805-00-90-852000	7801-00-00-000002	7801-00-00-000003	0101420	MS-0104220
A2-6 5C-50	7805-00-00-866000	7805-00-00-000001	7805-00-90-866000	7801-00-00-000002	7801-00-00-000003	0101420	MS-0104220
A2-6 5C-60	7807-00-00-000000	7807-00-00-000001	OA	7801-00-00-000002	7801-00-00-000003	0101420	MS-0104220
A2-6 16C	97Z00-00-90-5659P	97Z00-00-90-5660P	OA	7801-00-00-000002	7801-00-00-000003	—	MS-0104220
A2-6 16C-60	7819-00-00-000000	7819-00-00-000001	OA	7801-00-00-000002	7801-00-00-000003	0101420	MS-0104220
A2-6 16C-60	7819-00-00-852000	7819-00-00-000001	7819-00-90-852000	7801-00-00-000002	7801-00-00-000003	0101420	MS-0104220
A2-6 16C-60	7819-00-00-866000	7819-00-00-000001	7819-00-90-866000	7801-00-00-000002	7801-00-00-000003	0101420	MS-0104220
A2-6 3J-60	7813-00-00-000000	7813-00-00-000001	OA	7811-00-00-000002	7801-00-00-000003	0101420	MS-0104220
A2-6 3J-60	7813-00-00-852000	7813-00-00-000001	7813-00-90-852000	7811-00-00-000002	7801-00-00-000003	0101420	MS-0104220
A2-6 3J-60	7813-00-00-866000	7813-00-00-000001	7813-00-90-866000	7811-00-00-000002	7801-00-00-000003	0101420	MS-0104220
A2-6 20C	97Z00-00-90-8289M	97Z00-00-90-8290M	OA	97Z00-00-90-0312M	0100706	—	MS-0104219
A2-6 20C	7820-00-00-852000	7820-00-00-852001	7820-00-00-852002	97Z00-00-90-0312M	0100706	—	MS-0104220
A2-8 16C	97Z00-00-90-4853M	97Z00-00-90-4854M	OA	7801-00-00-000002	7801-00-00-000003	—	MS-0104621
A2-8 3J-60	7815-00-00-000000	7815-00-00-000001	OA	7811-00-00-000002	7801-00-00-000003	0101624	MS-0104621
A2-8 20C	97Z00-00-90-5693P	97Z00-00-90-5694P	OA	97Z00-00-90-5097P	MS-0103818	—	MS-0104625
A2-8 20C	97Z00-00-90-8340N	97Z00-00-90-8341N	OA	7811-00-00-000002	7801-00-00-000003	—	MS-0104625
A2-8 25C	97Z00-00-90-6395N	97Z00-00-90-6396N	OA	97Z00-00-90-2072M	97Z00-00-90-2073M	—	MS-0104625

### Collets & Collet Slot Spanners

Collet Style	Precision-machined Round Collet Part No.	Collet Slot Spanner Part Number	Collet Spanner Replacement Finger Set
5C	1001-00-19-Size	7899-00-00-000000	7899-00-00-00FNGR
16C	1717-00-19-Size	7901-00-00-00003J	7901-00-00-00FNGR
20C	1701-00-19-Size	7901-00-00-00020C	7901-00-00-00FNGR
25C	1801-00-19-Size	7901-00-00-00025C	7901-00-00-00FNGR
3J	1593-00-19-Size	7901-00-00-00003J	7901-00-00-00FNGR



Note: A link-up adapter is required for these chucks. Fill in the data sheet on page 27 and call Hardinge for a quotation. Collet Chucks for Hardinge Talent® CNC Lathes include a preconfigured link-up adapter.

# Style "S" Masters

## Collet Adaptation Chucks for CNC Lathes

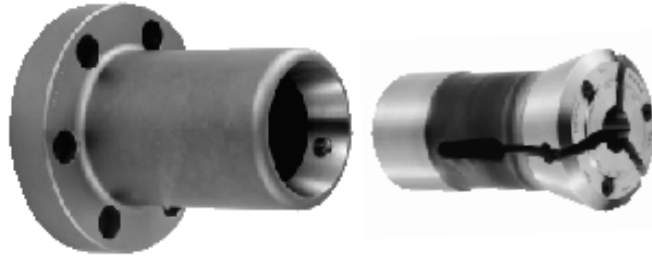
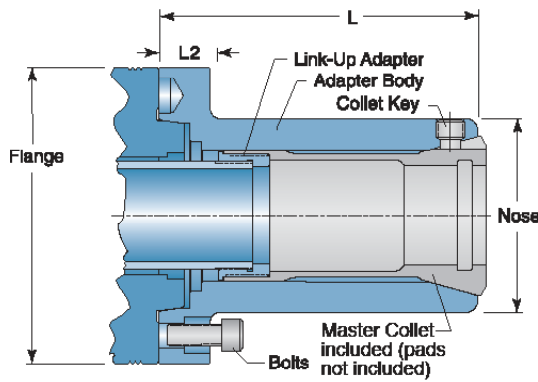

Collets and pads sold separately unless indicated otherwise.

### Style "S" Collet Adaptation Chucks - Dimensions

Spindle-to-Collet	Assembly Part Number	Spindle	Length L	Length L2	Flange OD	Nose OD	Collet Thru-Capacity
A2-5 S15-55	7823-00-00-000000	A2-5	5.500" (139.70)	1.000" (25.40)	5.250" (133.35)	3.250" (82.55)	1.500" (38.10)
A2-6 S20	7837-00-00-000200*	A2-6	5.500" (139.70)	1.125" (28.57)	6.500" (165.10)	4.250" (107.95)	2.000" (50.80)
A2-6 S20	7837-00-00-852200*	A2-6	5.500" (139.70)	1.125" (28.57)	6.500" (165.10)	4.250" (107.95)	2.000" (50.80)
A2-6 S20-65	97Z00-00-90-8332N	A2-6	6.500" (165.10)	1.125" (28.57)	6.500" (165.10)	4.250" (107.95)	2.000" (50.80)
A2-6 S20-70	97Z00-00-90-5798P	A2-6	7.000" (177.80)	1.125" (28.57)	6.500" (165.10)	4.250" (107.95)	2.000" (50.80)
A2-6 S20	97Z00-00-90-8955N	A2-6	8.000" (203.20)	1.125" (28.57)	6.500" (165.10)	4.250" (107.95)	2.000" (50.80)
A2-6 S26	97Z00-00-90-8460P*	A2-6	5.620" (142.74)	1.125" (28.57)	6.500" (165.10)	5.250" (133.35)	2.625" (66.67)
A2-6 S26	7850-00-00-866000*	A2-6	5.620" (142.74)	1.125" (28.57)	6.500" (165.10)	5.250" (133.35)	2.625" (66.67)
A2-6 S26-65	97Z00-00-90-9619N*	A2-6	6.500" (165.10)	1.125" (28.57)	6.500" (165.10)	5.250" (133.35)	2.625" (66.67)
A2-6 S26-75	97Z00-00-90-7028P*	A2-6	7.500" (190.50)	1.125" (28.57)	6.500" (165.10)	5.250" (133.35)	2.625" (66.67)
A2-6 S30	97Z00-00-90-7816N*	A2-6	7.125" (180.98)	1.125" (28.57)	6.500" (165.10)	5.500" (139.70)	3.000" (76.20)
A2-8 S26	7837-00-00-000300*	A2-8	6.250" (158.75)	1.250" (31.75)	8.250" (209.55)	5.500" (139.70)	2.625" (66.67)
A2-8 S26-75	97Z00-00-90-2170M	A2-8	7.500" (190.50)	1.250" (31.75)	8.250" (209.55)	5.500" (139.70)	2.625" (66.67)
A2-8 S26	97Z00-00-90-2557M	A2-8	8.500" (215.90)	1.250" (31.75)	8.250" (209.55)	5.500" (139.70)	2.625" (66.67)
A2-8 S30	97Z00-00-90-9352P*	A2-8	7.125" (180.97)	1.250" (31.75)	8.250" (209.55)	5.500" (139.70)	3.000" (76.20)
A2-8 S30	7850-00-90-107800*	A2-8	7.125" (180.97)	1.250" (31.75)	8.250" (209.55)	5.500" (139.70)	3.000" (76.20)
A2-11 S26	97Z00-00-90-6444P	A2-11	9.250" (234.95)	4.750" (120.65)	11.000" (279.40)	5.500" (139.70)	2.625" (66.67)

### Collet Adaptation Chucks Parts List and Style "S" Master Collets

Spindle-to-Collet	Assembly Part Number	Adapter Body	Link-Up Adapter	Collet Key	Inch Bolts	Metric Bolts	Master Collet Part Number
A2-5 S15-55	7823-00-00-000000	7823-00-00-000001	OA	7823-00-00-000002	0101216	MS-0104019	5015-00-00-000000
A2-6 S20	7837-00-00-000200*	7837-00-00-000201	OA	7825-00-00-000002	0101420	MS-0104220	95021-43-00-9147C
A2-6 S20	7837-00-00-852200*	7837-00-00-000201	7837-00-90-852200	7825-00-00-000002	0101420	MS-0104220	95021-43-00-9147C
A2-6 S20-65	97Z00-00-90-8332N	97Z00-00-90-8333N	OA	7825-00-00-000002	0101420	MS-0104220	5021-00-00-000000
A2-6 S20-70	97Z00-00-90-5798P	97Z00-00-90-5799P	OA	7825-00-00-000002	—	MS-0104220	5021-00-00-000000
A2-6 S20	97Z00-00-90-8955N	97Z00-00-90-8956N	OA	7825-00-00-000002	0101420	MS-0104220	5021-00-00-000000
A2-6 S26	97Z00-00-90-8460P*	97Z00-00-90-8464P	OA	7829-00-00-000002	0101420	MS-0104220	8041-00-00-000000
A2-6 S26	7850-00-00-866000*	97Z00-00-90-8464P	7850-00-90-866000	7829-00-00-000002	0101420	MS-0104221	8041-00-00-000000
A2-6 S26-65	97Z00-00-90-9619N*	97Z00-00-90-7068L	OA	7829-00-00-000002	0101420	MS-0104220	8041-00-00-000000
A2-6 S30	97Z00-00-90-7816N*	97Z00-00-90-7817N	OA	7829-00-00-000002	0101420	MS-0104220	95027-43-00-3333G
A2-8 S26	7837-00-00-000300*	7837-00-00-000301	OA	7829-00-00-000002	—	MS-0104621	8041-00-00-000000
A2-8 S26-75	97Z00-00-90-2170M	97Z00-00-90-2180M	OA	97Z00-00-90-2181M	0101624	MS-0104621	5113-00-00-000000
A2-8 S26	97Z00-00-90-2557M	97Z00-00-90-2558M	OA	97Z00-00-90-2559M	0101624	MS-0104621	5113-00-00-000000
A2-8 S30	97Z00-00-90-9352P*	97Z00-00-90-9353P	OA	7829-00-00-000002	—	MS-0104621	95027-43-00-3333G
A2-8 S30	7850-00-90-107800*	97Z00-00-90-9353P	7850-00-90-107801	7829-00-00-000002	—	MS-0104620	95027-43-00-3333G

### Collet Slot Spanner

Collet Style	Collet Slot Spanner Part Number	Collet Spanner Replacement Finger Set
S15	7901-00-00-000S15	7899-00-00-0015FNG
S20	7901-00-00-000S20	7901-00-00-00SFNG
S26	7901-00-00-000S26	7901-00-00-00SFNG
S30	7901-00-00-000S30	7901-00-00-00SFNG



Note: Collet Chucks for Hardinge Talent® CNC Lathes include a preconfigured link-up adapter. All others require a link-up adapter to be manufactured on application (OA). Fill in the data sheet on page 27 and call Hardinge for a quotation.

\* Master collet included with collet adaptation chuck. Pads sold separately.

(Millimeters in Parentheses)

# Spindle-to-Spindle

## Collet Adaptation Chucks for CNC Lathes

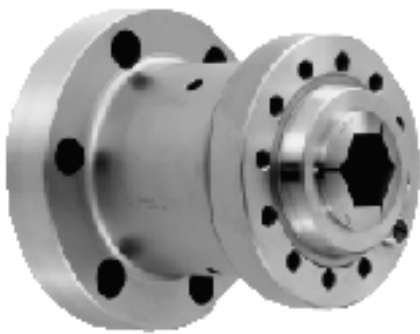

A2-6 to A2-5 16C  
Collets Sold Separately

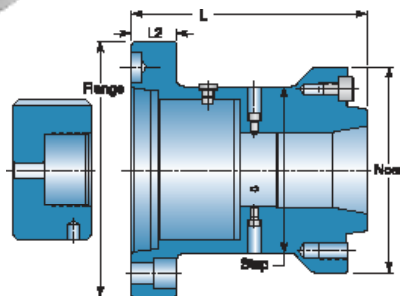

A2-6 to A2-5 16C

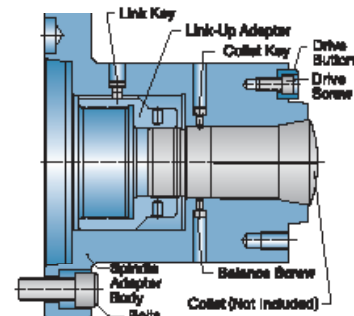

A2-8 to A2-5 16C

### Spindle-to-Spindle Collet Adaptation Chucks - Dimensions

Spindle-to Collet	Assembly Part Number	Spindle	Length L	Length L2	Flange OD	Nose OD	Thru-Capacity
A2-5 to A2-5 16C	7833-00-00-000000	A2-5	6.125" (155.57)	—	5.250" (133.35)	—	1.625" (41.27)
A2-5 to A2-5 16C	7833-00-00-645000	A2-5	6.125" (155.57)	—	5.250" (133.35)	—	1.625" (41.27)
A2-6 to A2-5 16C	7903-00-00-000000	A2-6	6.000" (152.40)	1.125" (28.57)	6.500" (165.10)	5.250" (133.35)	1.625" (41.27)
A2-6 to A2-5 16C	7903-00-00-852000	A2-6	6.000" (152.40)	1.125" (28.57)	6.500" (165.10)	5.250" (133.35)	1.625" (41.27)
A2-6 to A2-5 16C	7903-00-00-866000	A2-6	6.000" (152.40)	1.125" (28.57)	6.500" (165.10)	5.250" (133.35)	1.625" (41.27)
A2-6 to A2-6 20C	97Z00-00-90-0310M	A2-6	8.000" (203.20)	1.125" (28.57)	6.500" (165.10)	6.500" (165.10)	2.000" (50.80)
A2-6 to A2-6 20C	97Z00-00-90-6695K	A2-6	8.650" (219.71)	1.125" (28.57)	6.500" (165.10)	6.500" (165.10)	2.000" (50.80)
A2-8 to A2-5 16C	97Z00-00-90-0546N	A2-8	6.000" (152.40)	1.250" (31.75)	8.250" (209.55)	5.250" (133.35)	1.625" (41.27)
A2-8 to A2-5 16C	97Z00-00-90-8557P	A2-8	7.000" (177.80)	1.250" (31.75)	8.250" (209.55)	5.250" (133.35)	1.625" (41.27)

(Millimeters in Parentheses)

### Spindle-to-Spindle Collet Adaptation Chucks - Parts List

Component	A2-5 to 2-5 16C Part Number	A2-5 to 2-5 16C Part Number	A2-6 to A2-5 16C Part Number	A2-6 to A2-5 16C Part Number	A2-6 to A2-6 20C Part Number	A2-6 to A2-6 20C Part Number	A2-8 to A2-5 16C Part Number	A2-8 to A2-5 16C Part Number
Assembly	7833-00-00-000000	7833-00-00-645000	7903-00-00-000000	7903-00-00-852000 7903-00-00-866000	97Z00-00-90-0310M	97Z00-00-90-6695K	97Z00-00-90-0546N	97Z00-00-90-8557P
Adapter Body	7835-00-00-000000	7835-00-00-000000	7905-00-00-000000	7905-00-00-000000	97Z00-00-90-0311M	97Z00-00-90-6696K	97Z00-00-90-0547N	97Z00-00-90-8556P
Link Key	7839-00-00-000000	7839-00-00-000000	7865-00-00-000001	7865-00-00-000001	—	—	—	—
Collet Key	7841-00-00-000000	7841-00-00-000000	7801-00-00-000002	7801-00-00-000002	7839-00-00-000020	7839-00-00-000000	7801-00-00-000002	7801-00-00-000002
Drive Button	A2-0011920	A2-0011920	A2-0011920	A2-0011920	CL-0011920	CL-0011920	A2-0011920	A2-0011920
Button Screw	A2-0011920-S	A2-0011920-S	A2-0011920-S	A2-0011920-S	CL-0011920-01	CL-0011920-01	A2-0011920-S	A2-0011920-S
Linkup Adapter	OA	7833-00-90-645000	OA	7903-00-90-852000 7903-00-90-866000	OA	OA	OA	OA
Balance Screw	0550908	0550908	7801-00-00-000003	7801-00-00-000003	0100706	0100905	7801-00-00-000003	7801-00-00-000003
Inch Bolts	0101244	0101244	—	—	—	—	—	—
Metric Bolts	MS-0104028	MS-0104028	MS-0104220	MS-0104220	MS-0104220	MS-0104219	MS-0104620	MS-0104620
Collet	1717-00-19-Size	1717-00-19-Size	1717-00-19-Size	1717-00-19-Size	1701-00-19-Size	1701-00-19-Size	1717-00-19-Size	1717-00-19-Size

Note: Collet Chucks for Hardinge Talent® CNC Lathes include a preconfigured link-up adapter. All others require a link-up adapter to be manufactured on application (OA). Fill in the data sheet on page 27 and call Hardinge for a quotation.

# Style "B" Stationary Dead-Length Collet Adaptation Chucks for CNC Lathes

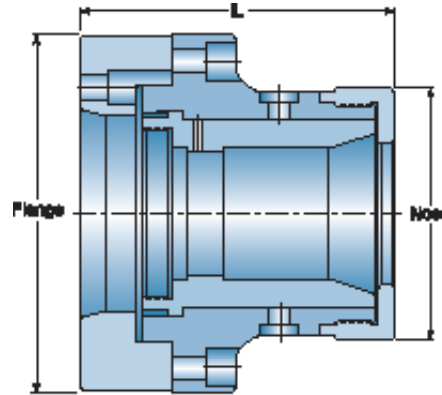

Collets sold separately.

## Style "B" Dead-Length Collet Adaptation Chuck – Stationary Collets

Spindle-to-Collet	Assembly Part Number	Spindle	OAL* Length L	Flange OD	Nose OD	Thru-Capacity
<b>DL 21</b>	<b>#21 Brown &amp; Sharpe Collets</b>					
A5-DL-21	7799-00-00-010000	A2-5	4.910" (124.71)	5.250" (133.35)	3.170" (80.51)	1.060" (26.92)
A6-DL-21	7799-00-00-020000	A2-6	4.910" (124.71)	6.450" (163.83)	3.170" (80.51)	1.060" (26.92)
110MM-DL-21	7799-00-00-030000	110 mm	4.910" (124.71)	6.450" (163.83)	3.170" (80.51)	1.060" (26.92)
140MM-DL-21	7799-00-00-040000	140 mm	4.910" (124.71)	6.450" (163.83)	3.170" (80.51)	1.060" (26.92)
<b>DL 21x4</b>	<b>#21 Brown &amp; Sharpe Collets</b>					
A4-DL-21x4	7799-00-00-050000	A2-4	4.910" (124.71)	4.000" (101.60)	3.170" (80.51)	1.060" (26.92)
A5-DL-21x4	7799-00-00-060000	A2-5	4.910" (124.71)	4.250" (107.95)	3.170" (80.51)	1.060" (26.92)
110MM-DL-21x4	7799-00-00-070000	110 mm	4.910" (124.71)	4.400" (111.76)	3.170" (80.51)	1.060" (26.92)
<b>DL 22</b>	<b>#22 Brown &amp; Sharpe Collets</b>					
A4-DL-22	7799-00-00-080000	A2-4	6.330" (160.78)	5.450" (138.43)	3.685" (93.59)	1.250" (31.75)
A5-DL-22	7799-00-00-090000	A2-5	6.330" (160.78)	5.450" (138.43)	3.685" (93.59)	1.250" (31.75)
A6-DL-22	7799-00-00-100000	A2-6	6.330" (160.78)	6.450" (163.83)	3.685" (93.59)	1.250" (31.75)
110MM-DL-22	7799-00-00-110000	110 mm	6.330" (160.78)	5.450" (138.43)	3.685" (93.59)	1.250" (31.75)
140MM-DL-22	7799-00-00-120000	140 mm	6.330" (160.78)	6.450" (163.83)	3.685" (93.59)	1.250" (31.75)
<b>DL 42</b>	<b>B42 Index Collets or Special S10 Master Collet</b>					
A5-DL-42	7799-00-00-130000	A2-5	5.955" (151.25)	6.450" (163.83)	4.188" (106.37)	1.620" (41.14)
A6-DL-42	7799-00-00-140000	A2-6	5.955" (151.25)	6.450" (163.83)	4.188" (106.37)	1.620" (41.14)
A8-DL-42	7799-00-00-150000	A2-8	6.200" (157.48)	8.450" (214.63)	4.188" (106.37)	1.620" (41.14)
110MM-DL-42	7799-00-00-160000	110 mm	5.955" (151.25)	6.450" (163.83)	4.188" (106.37)	1.620" (41.14)
140MM-DL-42	7799-00-00-170000	140 mm	5.955" (151.25)	6.450" (163.83)	4.188" (106.37)	1.620" (41.14)
<b>DL 60</b>	<b>B60 Index Collets or Special S16/S20 Master Collets</b>					
A5-DL-60	7799-00-00-180000	A2-5	5.950" (151.13)	7.250" (184.15)	5.125" (130.17)	2.370" (60.19)
A6-DL-60	7799-00-00-190000	A2-6	5.950" (151.13)	7.450" (189.23)	5.125" (130.17)	2.370" (60.19)
A8-DL-60	7799-00-00-200000	A2-8	6.150" (156.21)	8.450" (214.63)	5.125" (130.17)	2.370" (60.19)
110MM-DL-60	7799-00-00-210000	110 mm	5.950" (151.13)	7.250" (184.15)	5.125" (130.17)	2.370" (60.19)
140MM-DL-60	7799-00-00-220000	140 mm	5.950" (151.13)	7.250" (184.15)	5.125" (130.17)	2.370" (60.19)
<b>DL 90</b>	<b>DIN 90 Collets or Special S26 Master Collets</b>					
A6-DL-90	7799-00-00-230000	A2-6	7.660" (194.56)	8.450" (214.63)	6.000" (152.40)	3.150" (80.00)
A8-DL-90	7799-00-00-240000	A2-8	7.660" (194.56)	8.450" (214.63)	6.000" (152.40)	3.150" (80.00)
140MM-DL-90	7799-00-00-250000	140 MM	7.460" (189.48)	8.450" (214.63)	6.000" (152.40)	3.150" (80.00)

Note: \*Overall Length (OAL) is for chuck assembly only and may vary depending on spindle mount.  
x4 = 4 inch flange for sub-spindle lathes.

(Millimeters in Parentheses)

# Dead-Length

## Collet Adaptation Chucks for CNC Lathes

Master Collet included with S20, S26, S30 and S40 special master collet chucks on this page. All other collets sold separately.

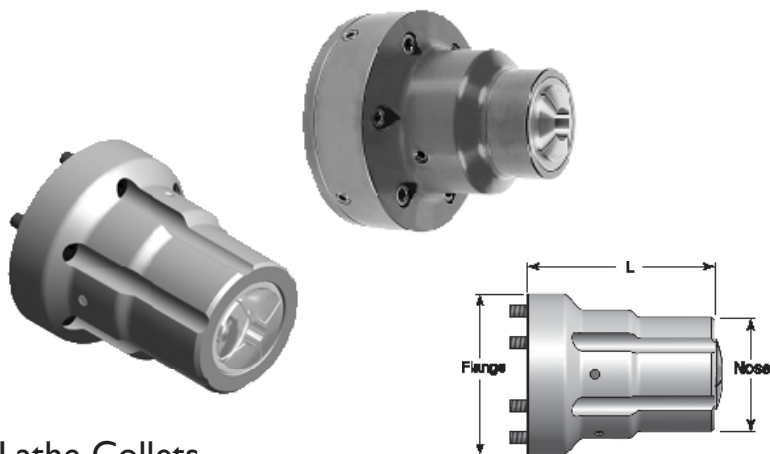

### Dead-Length Collet Adaptation Chuck – Lathe Collets

Spindle-to-Collet	Assembly Part Number	Spindle	OAL L	Flange OD	Nose OD	Thru-Capacity
<b>5C Standard 5C Collets</b>						
A5-5C-DL	7803-00-00-0005HB	A2-5	5.250" (133.35)	5.250" (133.35)	2.500" (63.50)	1.062" (26.97)
A6-5C-DL	7805-00-00-0005HB	A2-6	5.750" (146.05)	6.500" (165.10)	2.500" (63.50)	1.062" (26.97)
A8-5C-DL	7799-00-00-280000	A2-8	7.000" (177.80)	8.450" (214.63)	2.500" (63.50)	1.062" (26.97)
110 MM-5C-DL	7799-00-00-290000	110 mm	5.925" (150.49)	6.450" (163.83)	2.500" (63.50)	1.062" (26.97)
140 MM-5C-DL	7799-00-00-300000	140 mm	5.600" (142.24)	6.450" (163.83)	2.500" (63.50)	1.062" (26.97)
<b>16C Standard 16C Collets</b>						
A6-16C-DL	7819-00-00-0005HB	A2-6	6.750" (171.45)	6.500" (165.10)	3.750" (95.25)	1.625" (41.27)
A8-16C-DL	7821-00-00-0005HB	A2-8	6.750" (171.45)	8.250" (209.55)	3.750" (95.25)	1.625" (41.27)
140MM-16C-DL	7799-00-00-330000	140 mm	7.000" (177.80)	7.000" (177.80)	3.250" (82.55)	1.625" (41.27)
<b>16C Small Body, Standard 16C Collets</b>						
A5-16C-DLS	7817-00-00-0005HB	A2-5	6.125" (155.58)	5.250" (133.35)	3.375" (85.73)	1.625" (41.27)
110MM-16C-DLS	7799-00-00-350000	110 mm	6.220" (157.98)	5.250" (133.35)	3.250" (82.55)	1.625" (41.27)
<b>2J Standard 2J Collets</b>						
A5-2J-DL	7799-00-00-360000	A2-5	5.562" (141.27)	6.570" (166.87)	2.875" (73.02)	1.375" (34.92)
A6-2J-DL	7799-00-00-370000	A2-6	5.562" (141.27)	6.450" (163.83)	2.875" (73.02)	1.375" (34.92)
110MM-2J-DL	7799-00-00-380000	110 mm	5.812" (147.62)	5.750" (146.05)	2.875" (73.02)	1.375" (34.92)
140MM-2J-DL	7799-00-00-390000	140 mm	5.812" (147.62)	6.450" (163.83)	2.875" (73.02)	1.375" (34.92)
<b>3J Standard 3J Collets</b>						
A6-3J-DL	7813-00-00-0005HB	A2-6	6.187" (157.14)	6.500" (165.10)	3.750" (95.25)	1.750" (44.45)
A8-3J-DL	7815-00-00-0005HB	A2-8	6.187" (157.14)	8.250" (209.55)	3.750" (95.25)	1.750" (44.45)
140MM-3J-DL	7799-00-00-420000	140 mm	6.500" (165.10)	7.000" (177.80)	3.250" (82.55)	1.750" (44.45)
<b>3J Small Body, Standard 3J Collets</b>						
A5-3J-DLS	7811-00-00-0005HB	A2-5	5.562" (141.27)	5.250" (133.35)	3.750" (95.25)	1.750" (44.45)
110MM-3J-DLS	7799-00-00-440000	110 mm	6.000" (152.40)	5.250" (133.35)	3.250" (82.55)	1.750" (44.45)
<b>22J Standard 22J Collets or Special S16 Master Collet</b>						
A6-22J-DL	7799-00-00-450000	A2-6	6.500" (165.10)	7.950" (201.93)	4.000" (101.60)	2.250" (57.15)
A8-22J-DL	7799-00-00-460000	A2-8	7.240" (183.89)	8.450" (214.63)	4.000" (101.60)	2.250" (57.15)
140MM-22J-DLS	7799-00-00-470000	140 mm	6.500" (165.10)	7.950" (201.93)	4.000" (101.60)	2.250" (57.15)
<b>35J Standard 35J Collets or Special S26 or S30</b>						
A8-35J-DL	7799-00-00-480000	A2-8	8.875" (225.42)	9.000" (228.60)	6.125" (155.57)	3.500" (88.90)
A11-35J-DL	7799-00-00-490000	A2-11	9.375" (238.12)	11.450" (290.83)	6.125" (155.57)	3.500" (88.90)
<b>S20 Special S20 Master Collet (Master Collet Included)</b>						
A5-S20-DLS	7799-00-00-500000	A2-5	6.375" (161.92)	7.950" (201.93)	4.435" (112.64)	2.000" (50.80)
A6-S20-DLS	7799-00-00-510000	A2-6	6.375" (161.92)	7.950" (201.93)	4.435" (112.64)	2.000" (50.80)
A8-S20-DLS	7799-00-00-520000	A2-8	7.058" (179.27)	8.450" (214.63)	4.435" (112.64)	2.000" (50.80)
110MM-S20-DLS	7799-00-00-530000	110 mm	6.375" (161.92)	7.950" (201.93)	4.435" (112.64)	2.000" (50.80)
140MM-S20-DLS	7799-00-00-540000	140 mm	6.375" (161.92)	7.950" (201.93)	4.435" (112.64)	2.000" (50.80)
<b>S26 Special S26 Master Collet (Master Collet Included)</b>						
A6-S26-DLS	7799-00-00-550000	A2-6	7.000" (177.80)	7.375" (187.32)	5.500" (139.70)	2.625" (66.67)
A8-S26-DLS	7799-00-00-560000	A2-8	7.170" (182.11)	8.450" (214.63)	5.500" (139.70)	2.625" (66.67)
140MM-S26-DLS	7799-00-00-570000	140 mm	7.000" (177.80)	7.375" (187.32)	5.500" (139.70)	2.625" (66.67)
<b>S30 Special S30 Master Collet (Master Collet Included)</b>						
A6-S30-DLS	7799-00-00-580000	A2-6	7.875" (200.02)	9.000" (228.60)	6.160" (156.46)	3.000" (76.20)
A8-S30-DLS	7799-00-00-590000	A2-8	7.875" (200.02)	9.000" (228.60)	6.160" (156.46)	3.000" (76.20)
A11-S30-DLS	7799-00-00-600000	A2-11	8.875" (225.42)	11.450" (290.83)	6.160" (156.46)	3.000" (76.20)
<b>S40 Special S40 Master Collet (Master Collet Included)</b>						
A8-S40-DLS	7799-00-00-610000	A2-8	8.375" (212.72)	10.000" (254.00)	7.500" (190.50)	4.000" (101.60)
A11-S40-DLS	7799-00-00-620000	A2-11	8.375" (212.72)	10.000" (254.00)	7.500" (190.50)	4.000" (101.60)

Note: Overall Length (OAL) is for chuck assembly only. OAL may vary depending on spindle mount.

(Millimeters in Parentheses)



# Collet Adaptation Chucks

For Hardinge TALENT GS and SV-Series Turning Centers



A2-5 16C-60



A2-6 S20

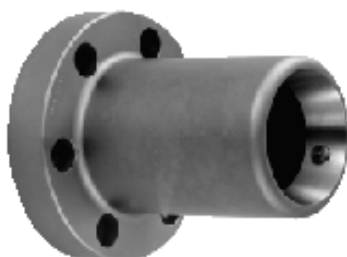

A2-5 to A2-5 16C

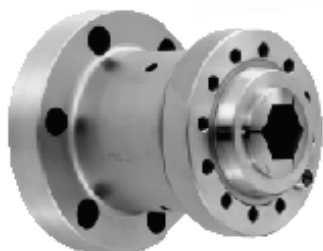

A2-6 to A2-5 16C



## Plain and Stepped Collet Adaptation Chucks

Spindle-to-Collet	Assembly Part Number	Lathe Spindle
A2-5 5C-50	7803-00-00-645000	A2-5
A2-5 16C-60	7817-00-00-645000	A2-5
A2-5 3J-55	7811-00-00-645000	A2-5
A2-6 5C-50	7805-00-00-852000	A2-6
A2-6 16C-60	7819-00-00-852000	A2-6
A2-6 3J-60	7813-00-00-852000	A2-6
A2-6 20C	7820-00-00-852000	A2-6
A2-6 5C-50	7805-00-00-866000	A2-6
A2-6 16C-60	7819-00-00-866000	A2-6
A2-6 3J-60	7813-00-00-866000	A2-6

(Refer to pages 3 and 4 for dimensions and parts lists)

## Style "S" Collet Adaptation Chucks

Spindle-to-Collet	Assembly Part Number	Lathe Spindle
A2-6 S20	7837-00-00-852200*	A2-6
A2-6 S26	7850-00-00-866000*	A2-6
A2-8 S30	7850-00-90-107800*	A2-8

\* Master Collet included with collet adaptation chuck.

Pads sold separately.

(Refer to page 5 for dimensions and parts lists)

## Spindle-to-Spindle Collet Adaptation Chucks

Spindle-to-Collet	Assembly Part Number	Lathe Spindle
A2-5 to A2-5 16C	7833-00-00-645000	A2-5
A2-6 to A2-5 16C	7903-00-00-852000	A2-6
A2-6 to A2-5 16C	7903-00-00-866000	A2-6

(Refer to page 6 for dimensions and parts lists)

## Style "B" Dead-Length® Collet Adaptation Chucks

Spindle-to-Collet	Assembly Part Number	Lathe Spindle
A2-5 to B42	7842-00-00-645000	A2-5
A2-6 to B60	7860-00-00-852000	A2-6
A2-6 to B60	7860-00-00-866000	A2-6

(Refer to page 10 for dimensions and parts lists)

# Style-B Dead-Length Collet Adaptation Chucks

For Hardinge TALENT GS- and SV-Series Turning Centers

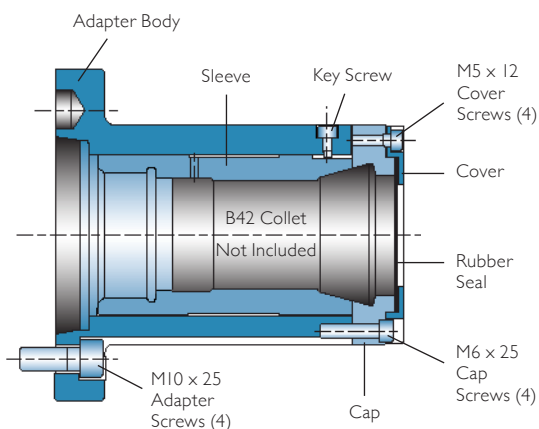

## Style-B Dead-Length Collet Adaptation Chuck for Hardinge Talent 6/45

The B42 system adapts the A2-5 spindle to accept B42 workholding and uses either B42 Solid or B42 Style S10 Master Collets and pads (sold separately). Dead-Length® design provides precise part length control.

### A2-5 to B42 – Parts List

Description	Part Number
<b>A2-5 to B42 Assembly</b>	<b>7842-00-00-645000</b>
- Adapter Body	7842-00-00-645001
- Sleeve	7842-00-00-645002
- Keyscrew	7842-00-00-645003
- M5 x .8 x 12 SHCS (4)	MS 0103516
- Cover	7842-00-00-645004
- Rubber Seal (5)	7842-00-00-645005
- M6 x 1 x 25 SHCS (4)	MS 0103619
- Cap	7842-00-00-645006
- M10 x 1.5 x 25 SHCS (4)	MS 0104019
- Teflon Sleeve	3719-00-00-000012
<b>Round Smooth Collets, Master Collets and Pads</b>	
- B42 Solid Collet	3719-00-19-SIZE
- B42 S10 Master Collet	5205-00-00-000000
- S10 Pads	5601-00-19-SIZE

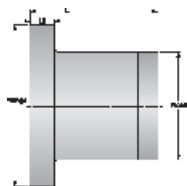

## Dimensions

Spindle-to-Collet	Assembly Part Number	Spindle	Length L	Length L2	Flange OD	Nose OD	Thru-Capacity
A2-5 to B42	7842-00-00-645000	A2-5	5.780" (146.81)	.820" (20.82)	5.500" (139.70)	3.660" (92.96)	1.625" (41.27)
A2-6 to B60	7860-00-00-852000	A2-6	6.208" (157.68)	—	6.500" (165.10)	6.500" (165.10)	2.375" (60.32)
A2-6 to B60	7860-00-00-866000	A2-6	6.208" (157.68)	—	6.500" (165.10)	6.500" (165.10)	2.375" (60.32)

(Millimeters in Parentheses)

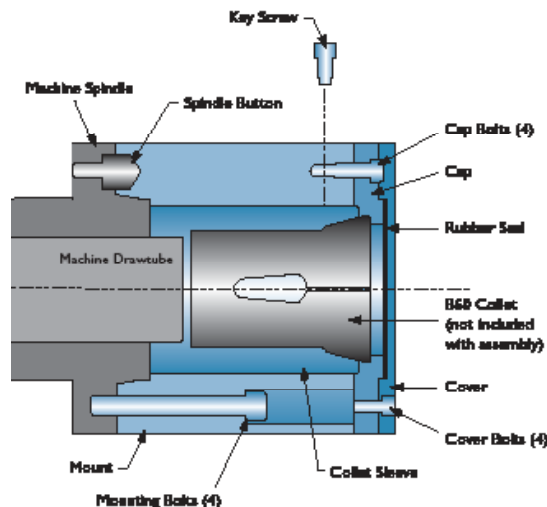

## Style-B Dead-Length Collet Adaptation Chuck for Hardinge Talent 8/52 and 8/66

The B60 system adapts the A2-6 spindle to accept B60 workholding and uses either B60 Solid or B60 Style S16 or S20 Master Collets and pads (sold separately). Dead-Length® design provides precise part length control.

### A2-6 to B60 – Parts List

Description	Part Number
<b>A2-6 to B60 Assembly (8/52)</b>	<b>7860-00-00-852000</b>
<b>A2-6 to B60 Assembly (8/66)</b>	<b>7860-00-00-866000</b>
- Adapter Body	7860-00-00-852001
- Sleeve (8/52)	7860-00-00-852002
- Sleeve (8/66)	7860-00-00-866002
- Key Screw	7860-00-00-852003
- M8 x 1.25 x 20 SHCS (4)	MS 0103818
- Cover	7860-00-00-852004
- Cap Seal	7860-00-00-852005
- M6 x 1.0 x 16M (4)	MS 0103617
- Cap	7860-00-00-852006
- M12 x 1.75 x 90MM SHCS (4)	MS 0104231
<b>Round Smooth Collets, Master Collets and Pads</b>	
- B60 Solid Collet	3725-07-19-SIZE
- B60 S16 Master Collet	5207-00-00-000000
- B60 S20 Master Collet	5209-07-00-000000
- S16 Pads	5607-00-19-SIZE
- S20 Pads	5609-00-19-SIZE

# B42 Dead-Length Collet Adaptation Chucks

## for Hardinge QUEST TwinTurn 65 Turning Center

### Style-B Dead-Length Collet Adaptation Chuck for Hardinge QUEST TwinTurn 65

The B42 collet chuck is a Dead-Length® system designed to provide very precise length control of the workpiece. This exact part-length feature makes it possible to accurately transfer parts from one spindle to the other within .0005" (.0127 mm). The system uses either B42 Solid or B42 Style S10 Master Collets and pads (sold separately).

The B42 Coolant Nozzle is threaded onto the end of the through-spindle coolant assembly before the unit is inserted into the draw tube. Coolant nozzle included – part number 3111-00-00-000011.

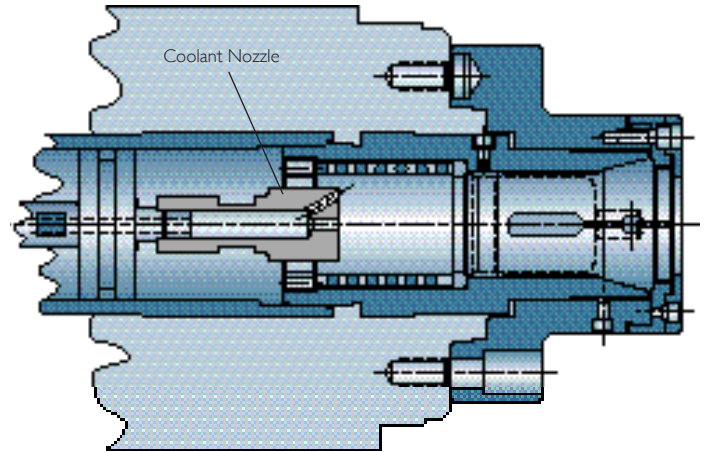

### A2-6 to B42-Style Dead-Length Collet Adaptation Chuck - Dimensions

Spindle-to-Collet	Assembly Part Number	Spindle	Length L	Length L2	Flange OD	Nose OD	Thru-Capacity
A2-6 to B42	<b>3719-00-00-000001</b>	A2-6	4.042" (102.67)	1.600" (40.64)	6.300" (160.02)	3.890" (98.81)	1.656" (42.07)

(Millimeters in Parentheses)

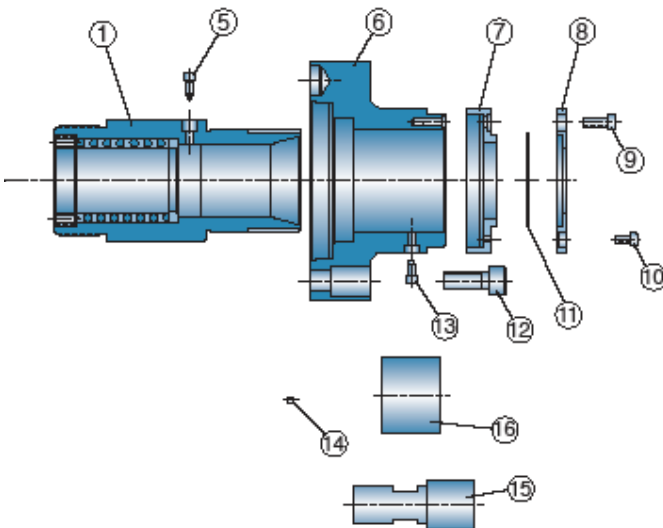

### A2-6 to B42-Style Dead-Length Collet Adaptation Chuck - Parts List

Item	Description	Qty	Part Number
—	<b>Complete Assembly</b>	<b>1</b>	<b>3719-00-00-000001</b>
1	- Spring Assembly	1	3719-00-00-000015
5	- Removable Keyscrew	1	3111-00-00-000007
6	- Mount	1	3719-00-00-000002
7	- Cap	1	3719-00-00-000003
8	- Cover	1	3719-00-00-000005
9	- M6 x 16MM SHCS	4	MS 0103617
10	- M5 x .8 x 10MM SHCS	4	MS 0103515
11	- Seal	6	3719-00-00-000006
12	- M10 x 1.5 x 25 SHCS	4	MS 0104019
13	- Keyscrew	1	3111-00-00-000008
14	- Plug	6	3075-00-00-000004
15	- Coolant Nozzle	1	3111-00-00-000011
16	- Teflon Sleeve	3	3719-00-00-000012

Stationary collet systems are noted for their length control feature. The collet does not move when it is closed. It is inserted into the collet chuck or spindle adapter and held in place with a cap. The collet is closed by a sleeve which moves forward on the collet closing angle.

These units can be used for Dead-Length® applications on lathes with A2-6 spindle noses. Separate link-ups will be needed for other lathes. Collet sold separately.

### B42 Collets

Round Smooth Collet	Part Number
- B42 Solid Collet	3719-00-19-SIZE
- B42 S10 Master Collet	5205-00-00-000000
- S10 Pads	5601-00-19-SIZE

NOTE: See Brochure 2348 for additional collets, stop assemblies, guide bushings, sleeves and coolant nozzles.

# A2-6 to B65 Dead-Length Collet Adaptation Chuck

## for Hardinge QUEST TwinTurn 65 CNC Turning Center

### B65 Collet Chuck

The B65 collet chuck is a Dead-Length® system designed to provide very precise length control of the workpiece. This exact part-length feature makes it possible to accurately transfer parts from one spindle to the other within .0005" (.0127 mm). The system uses either B65 Solid or B65 Style S22 Master Collets and pads (sold separately).

The B65 Stationary Collet is used on the Hardinge QUEST TwinTurn 65 CNC Turning Center and other machines that use B65 Stationary Collet Systems.



### A2-6 to B65-Style Dead-Length Collet Adaptation Chuck - Dimensions

Spindle-to-Collet	Assembly Part Number	Spindle	Length L	Length L2	Flange OD	Nose OD	Thru-Capacity
A2-6 to B65	<b>3757-00-00-000000</b>	A2-6	3.900" (99.06)	2.150" (54.61)	6.300" (160.02)	5.563" (141.30)	2.559" (64.99)

(Millimeters in Parentheses)

### A2-6 to B65-Style Dead-Length Collet Adaptation Chuck - Parts List

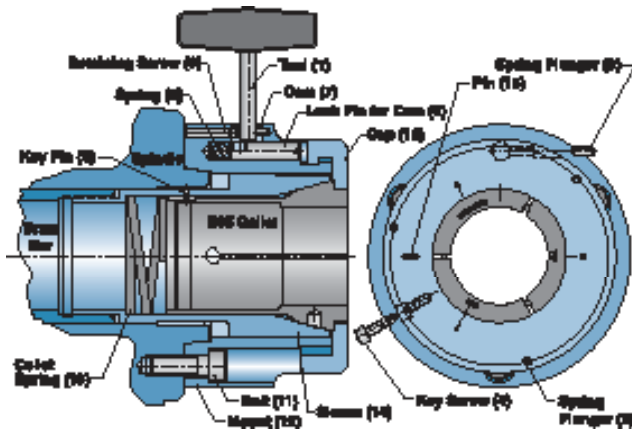

Item	Description	Qty	Part Number
—	<b>Complete Assembly</b>	<b>1</b>	<b>3757-00-00-000000</b>
1	- Tool	1	3757-00-00-000009
2	- Spring Plunger	3	CE-0375711
3	- Spring Plunger	1	CE 0375712
4	- Key Screw	1	3757-00-00-000008
5	- Key Pin	1	3757-00-00-000007
6	- Retaining Screw	1	3757-00-00-000006
7	- Cam	1	3757-00-00-000005
8	- Spring	1	CE-0360047100M
9	- Lock Pin for Cam	1	3757-00-00-000004
10	- Cap	1	3757-00-00-000002
11	- M12 x 1.75 x 30 SHCS	3	MS-0104220
12	- B65 Mount	1	3757-00-00-000001
13	- Collet Spring	1	CE-0375710
14	- Collet Sleeve	1	3757-00-00-000003
15	- 1/8" Dia. x 5/16" Dowel	1	0004628

Stationary collet systems are noted for their length control feature. The collet does not move when it is closed. It is inserted into the collet chuck or spindle adapter and held in place with a cap. The collet is closed by a sleeve which moves forward on the collet closing angle. The B65 standard collet has RTV sealant in slots up to the Teflon chip sleeve and seal.

These units can be used for Dead-Length® applications on lathes with A2-6 spindle noses. Separate link-ups will be needed for other lathes. Collet sold separately.

### B65 Collets

Round Smooth Collet	Part Number
B65 Solid Collet	3743-00-19-Size
B65 S22 Master Collet	5311-00-00-000000
S22 Pads	5611-00-19-Size

NOTE: See Brochure 2348 for additional collets, stop assemblies, guide bushings, sleeves and coolant nozzles.

# A2-6 to #22 B&S Collet Adaptation Chuck

## for Hardinge QUEST TwinTurn 65 CNC Turning Center

The #22 B&S Dead-Length Collet Chuck System will provide minimal tool interference while achieving shorter cycle times when your work is under 1/4" diameter.

The nose diameter is just 3.56" x 2.460" (90.42 x 62.48mm) long with an overall chuck length of 4.060" (103.12mm) from the spindle locating surface. This stationary collet design provides precise length control of the workpiece. The Dead-Length feature makes it possible to accurately transfer parts from one spindle to the other within .0005" (.0127mm). The system uses either #22, #22Y or #22SC B&S collets (sold separately).

The #22 B&S Stationary Collet is used on the Hardinge QUEST TwinTurn 65 CNC Turning Center and other machines that use #22 B&S Stationary Collet Systems.

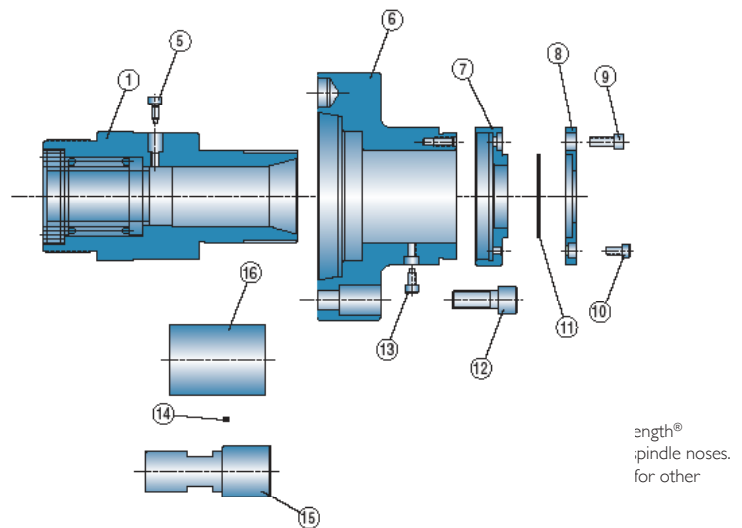
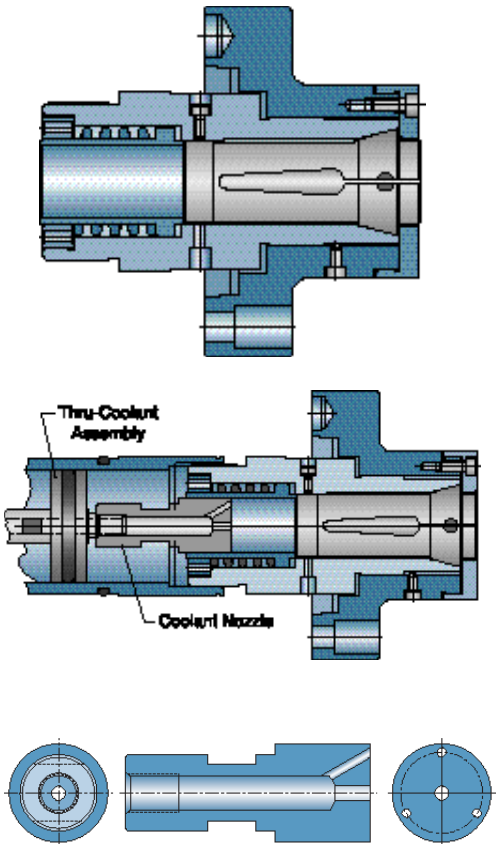

The #22 B&S Coolant Nozzle is threaded onto the end of the through-spindle coolant assembly before the unit is inserted into the draw tube. A coolant nozzle is included with each assembly. Part Number 3111-00-00-000011.

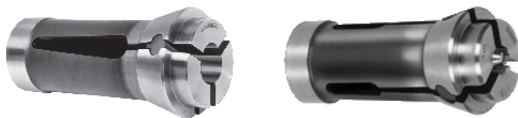

### #22 B&S Collets

Round Smooth Collet	Part Number
#22 B&S Standard	3743-00-19-Size
B65 S22 Master Collet	3227-00-19-Size
#22Y B&S	3109-00-19-Size

NOTE: See Brochure 2348 for additional collets and stop assemblies.

### A2-6 to #22 B&S Collet Assembly and Parts List

Item	Description	Qty	Part Number
—	<b>TT65 to #22 B&amp;S Collet Assembly</b>	1	<b>3111-00-00-000001</b>
1	- Spring and Sleeve Assembly	1	3111-00-00-000015
5	- Removable Keyscrew	1	3111-00-00-000007
6	- Mount	1	3111-00-00-000002
7	- Cap	1	3111-00-00-000003
8	- Cover	1	3111-00-00-000005
9	- M6 x 16MM SHCS	4	MS 0103617
10	- M5 x .8 x 10MM SHCS	4	MS 0103515
11	- Seal	6	3111-00-00-000006
12	- M10 x 1.5 x 25MM SHCS	4	MS 0104019
13	- Keyscrew	1	3111-00-00-000008
14	- Plug	6	3075-00-00-000004
15	- Coolant Nozzle	1	3111-00-00-000011
16	- Teflon Sleeve	3	3111-00-00-000012

NOTE: Keyed collets are not standard.

Millimeters in Parenthesis.

# A2-5 to #22 B&S Collet Adaptation Chuck

for all Hardinge I6C spindle machines

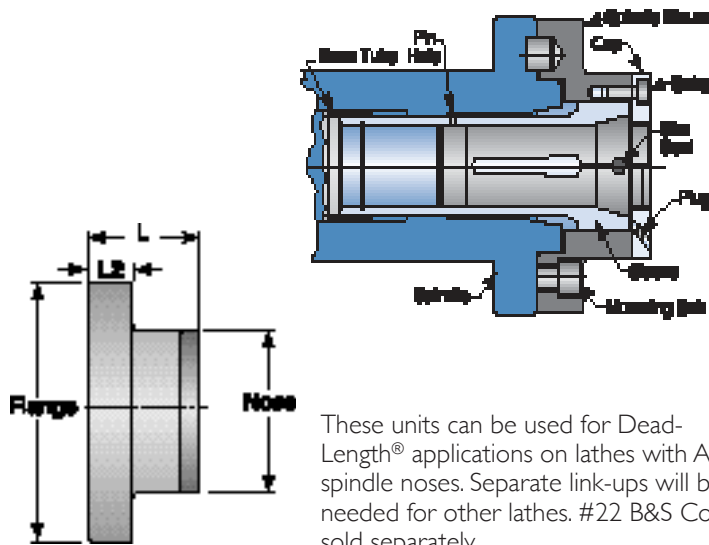

These units can be used for Dead-Length® applications on lathes with A2-5 spindle noses. Separate link-ups will be needed for other lathes. #22 B&S Collets sold separately.

## A2-5 to #22 B&S Collet Adaptation Chuck - Parts List

Description	Qty	Part Number
Sleeve	1	1717-09-00-000003
Mount	1	1717-09-00-000001
Cap	1	1717-09-00-000002
Cap Bolts - M6 x 16MM SHCS	4	MS 0103617
Mounting - M10 x 1.5 x 25 SHCS	3	MS 0104019
Slinger Hole Plug	6	1717-09-00-000004
Orientation Pin 1/8" Dia. (Option)	1	3757-00-00-000007
Teflon Sleeve	3	3111-00-00-000012

## #22 Collets

Round Smooth Collet	Part Number
#22 B&S Standard	3111-00-19-Size
#22SC B&S Stop	3227-00-19-Size
#22Y B&S	3109-00-19-Size

NOTE: See Brochure 2348 for additional collets and stop assemblies.

## A2-5 I6C Spindle to #22 B&S Collet Adaptation Chuck

Spindle-to-Collet	Assembly Part Number	Spindle	Length L	Length L2	Flange OD	Nose OD	Thru-Capacity
A2-5 I6C to #22 B&S	<b>1717-09-00-000000</b>	A2-5	2.285" (58.03)	.915" (23.24)	5.500" (139.7)	3.400" (86.36)	1.25" (31.75)

(Millimeters in parentheses)

# A2-4 5C to #11 B&S Collet Adaptation Chuck

for Hardinge QUEST® GT27SP Gang-Tool CNC Lathe

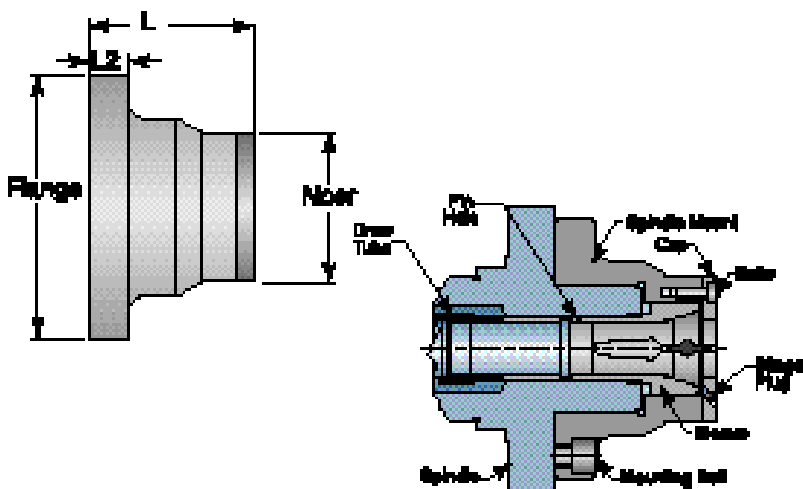

## A2-4 5C to #11 B&S Collet Adaptation Chuck - Parts List

Description	Qty	Part Number
Sleeve	1	3075-00-00-000003
Mount	1	3075-00-00-000001
Cap	1	3075-00-00-000002
M5 x .8 x 16MM SHCS	4	MS 0103517
M10 x 1.5 x 25 SHCS	3	MS 0104019
Slinger Hole Plug	6	3075-09-00-000004
Orientation Pin (Option)	1	3/2" Diameter Pin

## #11 Collets

Round Smooth Collet	Part Number
#11 B&S Standard	3057-00-19-Size
#11 ISC B&S Stop	3217-00-19-Size
#11Y B&S	3055-00-19-Size

NOTE: See Brochure 2348 for additional collets and stop assemblies.

## A2-4 5C to #11 B&S Collet Adaptation Chuck

Model	Assembly Part Number	Spindle	Length L	Length L2	Flange OD	Step OD	Nose OD	Thru-Capacity
GT 5C	<b>3075-00-00-000000</b>	GT	3.120" (79.24)	.76" (19.30)	5.000" (127.00)	3.400" (86.36)	2.830" (71.88)	5/8" (21.82)

(Millimeters in parentheses)

# Cross Reference Guide by Machine Tool Builder

Machine Mfr.	Machine Model	Spindle	Spindle & Collet Style	Machine Bar Capacity	PULL-BACK Style Assembly Number	Dead-Length Model Number	DEAD-LENGTH Style Assembly Number
Ameri Seiki	GT-32	Main	A2-5-3J	1.30" (33.00)	7811-00-00-000000	A5-3J	7811-00-00-000500
Ameri Seiki	TC-1,TC-1L	Main	A2-5-3J	1.60" (40.64)	7811-00-00-000000	A5-3J	7811-00-00-000500
Ameri Seiki	TC-1LS,TC-2,TC-2L,TC-2LSMain	Main	A2-6-S20H	2.00" (50.80)	7837-00-00-000200	A6-S20-DLS	7799-00-00-510000
Ameri Seiki	TC-25L	Main	A2-6-S26	2.56" (65.02)	97Z00-00-90-8460P	A6-S26-DLS	7799-00-00-550000
Ameri Seiki	TC-25L,TC-3L,TC-3LS,TC-3XL	Main	A2-8-S26H	2.56"	(65.02)	7837-00-00-000300	A8-S26-DLS
7799-00-00-560000							
Ameri Seiki	TC-2L,TC-4L,TC-4LS,TC-4XL	Main	A2-8 S30H	3.00"	(76.20)	97Z00-00-90-9352P	A8-S30-DLS
7799-00-00-590000							
Bridgeport	Power Path	Main	A2-6 S20H	2.00" (50.80)	7837-00-00-000200	A6-S20-DLS	7799-00-00-510000
Cincinnati	Talon 208 (5000)	Main	A2-5 3J	1.35" (34.29)	7811-00-00-000000	A5-3J	7811-00-00-000500
Cincinnati	Talon 208 (3600)	Main	A2-6 3J	1.75" (44.45)	7813-00-00-000000	A6-3J	7813-00-00-000500
Cincinnati	AVGR200, Sub	Sub	A2-5 3J	1.65" (41.91)	7811-00-00-000000	A5-3J	7811-00-00-000500
Cincinnati	Hawk 150	Main	A2-5 S20H	2.00" (50.80)	OA	A5-S20-DLS	7799-00-00-500000
Cincinnati	AVGR200, C, MC, MS, S, T, MT,	Main	A2-6 S20H	2.00"	(50.80)	7837-00-00-000200	A6-S20-DLS
7799-00-00-510000							
	Falcon 200, Talon 208, Talon 210						
Cincinnati	Falcon 200	Main	A2-6 S26H	2.60" (66.04)	97Z00-00-90-8460P	A6-S26-DLS	7799-00-00-550000
Cincinnati	AVGR250, MS, T	Main	A2-6 S26H	2.75" (69.85)	97Z00-00-90-8460P	A6-S26-DLS	7799-00-00-550000
Cincinnati	Falcon 300	Main	A2-8 S26H	2.60" (66.04)	7837-00-00-000200	A8-S26-DLS	7799-00-00-550000
Cincinnati	Talon 208 B/B	Main	A2-8 S30H	2.75" (69.85)	97Z00-00-90-9352P	A8-S30-DLS	7799-00-00-590000
Cincinnati	Cinturn 15C	Main	A2-11 S50H	4.50" (114.30)	OA	A11-35J-DL	7799-00-00-490000
Clausing	CNC-100A, 100B	Main	A2-5 3J	2.08" (52.83)	7811-00-00-000000	A5-S20-DLS	7799-00-00-500000
Clausing	CNC-80A, 80U	Main	A2-5 16C	1.67" (42.41)	7817-00-00-000000	A5-16C	7817-00-00-000500
Clausing	CNC-200A, 200B	Main	A2-6 S26H	2.60" (66.04)	97Z00-00-90-8460P	A6-S26-DLS	7799-00-00-550000
Clausing	CNC-Storm 300A	Main	A2-8 S30H	3.26" (82.80)	97Z00-00-90-9352P	A8-S30-DLS	7799-00-00-590000
Daewoo	Puma 250B	Sub	140MM F/N	1.75" (44.45)	OA	140MM-3J-DL	7799-00-00-420000
Daewoo	Puma 4, 150G,	Main	A2-5 3J	1.50" (38.10)	7811-00-00-000000	A5-3J	7811-00-00-000500
Daewoo	Puma 6S, 6G	Main	A2-5 3J	1.54" (39.11)	7811-00-00-000000	A5-3J	7811-00-00-000500
Daewoo	Puma 200A, MA, SMA	Main	A2-5 3J	1.77" (44.95)	7811-00-00-000000	A5-3J	7811-00-00-000500
Daewoo	Lynx A, 200A, Puma 200A, Main	Main	A2-5 3J	1.75" (44.45)	7811-00-00-000000	A5-3J	7811-00-00-000500
	Puma 6S, 6G, Puma 230MA						
Daewoo	Lynx B, 200B, Puma 250A	Main	A2-6 S20H	2.00" (50.80)	7837-00-00-000200	A6-S20-DLS	7799-00-00-510000
Daewoo	Puma 200B, MB, SMB, Main	Main	A2-6 S20H	2.04" (51.81)	7837-00-00-000200	A6-S20-DLS	7799-00-00-510000
	Puma 8HC, 8HC-3A, Puma 8S						
Daewoo	Lynx LC, 200LC, Puma 230MSB	Main	A2-6 S26H	2.50"	(63.50)	97Z00-00-90-8460P	A6-S26-DLS
7799-00-00-550000							
Daewoo	Puma 200C, MC, SMC	Main	A2-6 S26H	2.55" (64.77)	97Z00-00-90-8460P	A6-S26-DLS	7799-00-00-550000
Daewoo	Puma 230C, 250	Main	A2-8 S30H	3.00" (76.20)	97Z00-00-90-9352P	A8-S30-DLS	7799-00-00-590000
Daewoo	Puma 10HC, 20HC, Puma 12S-3A	Main	A2-8 S30H	3.03"	(76.96)	97Z00-00-90-9352P	A8-S30-DLS
7799-00-00-590000							
Daewoo	Puma 12S	Main	A2-8 S30H	3.10" (78.74)	97Z00-00-90-9352P	A8-S30-DLS	7799-00-00-590000
Daewoo	Puma 12L-B, Puma 350A, MAMain	Main	A2-8 S35H	3.50" (88.90)	OA	A8-35J-DL	7799-00-00-
480000							
Daewoo	Puma 300C	Main	A2-11 S40H	4.00" (101.60)	OA	A11-S40-DLS	7799-00-00-620000
Daewoo	Puma 450A	Main	A2-11 S50H	4.50"(114.30)	OA	—	OA
Daewoo	Puma 12L-C, Puma 15, Puma 350B	Main	A2-11 S50H	4.70"	(119.38)	OA	A11-35J-DL
7799-00-00-490000							
Dainichi	F-15	Main	A2-5 3J	1.70" (43.18)	7811-00-00-000000	A5-3J	7811-00-00-000500
Dainichi	F-20	Main	A2-6 S20H	2.00" (50.80)	7837-00-00-000200	A6-S20-DLS	7799-00-00-510000
Dainichi	F-25	Main	A2-8 S26H	2.50" (63.50)	7837-00-00-000300	A8-S26-DLS	7799-00-00-590000
Dainichi	F-30	Main	A2-8 S30H	3.00" (76.20)	97Z00-00-90-9352P	A8-S30-DLS	7799-00-00-590000
Dainichi	F-35	Main	A2-8 S35H	3.50" (88.90)	OA	A8-35J-DL	7799-00-00-480000
Emco Maier	EMCOTRN-240, -340, -342Main	Main	A2-5-16C	1.73"	(43.94)	7817-00-00-000000	A5-3J
7817-00-00-000500							
Emco Maier	EMCOTRN-340T, -360, -465Main	Main	A2-6-S26H	2.55"	(64.77)	97Z00-00-90-8460P	A6-S26-DLS
7799-00-00-550000							
Emco Maier	EMCOTRN-360B/B	Main	A2-8-S30H	3.30"	(83.82)	97Z00-00-90-9352P	A8-35J-DL
7799-00-00-480000							
FEMCO	Durga 15E	Main	A2-5 3J	1.85" (46.99)	7811-00-00-000000	A5-3J	7811-00-00-000500
FEMCO	Durga WNCL 10	Main	A2-5 16C	1.33" (33.78)	7817-00-00-000000	A5-16C	7817-00-00-000500
FEMCO	WNCL 2040	Main	A2-6 S20H	1.85" (46.99)	97Z00-00-90-5798P	A6-S20-DLS	7799-00-00-510000
FEMCO	Durga 12E	Main	A2-6 S20H	2.00" (50.80)	97Z00-00-90-5798P	A6-S20-DLS	7799-00-00-510000
FEMCO	Durga 35E, WNCL 20	Main	A2-6 S20H	2.04" (51.81)	97Z00-00-90-5798P	A6-S20-DLS	7799-00-00-510000
FEMCO	WNCL 2040, 2060, 3560	Main	A2-6 S26H	2.56" (65.02)	97Z00-00-90-8460P	A6-S26-DLS	7799-00-00-550000
FEMCO	WNCL 2060, 3060, 35	Main	A2-8 S30H	2.93" (75.18)	97Z00-00-90-9352P	A8-S30-DLS	7799-00-00-590000
FEMCO	Durga 3060	Main	A2-8 S30H	3.03" (76.96)	97Z00-00-90-9352P	A8-S30-DLS	7799-00-00-590000
FEMCO	WNCL 3670B	Main	A2-11 S50H	4.75" (120.66)	OA	A11-35J-DL	7799-00-00-490000
Fortune	V-Turn 15, 1660A	Main	A2-5 3J	1.50" (38.10)	7811-00-00-000000	A5-3J	7811-00-00-000500
Fortune	V-Turn 2060	Main	A2-6 S20H	2.00" (50.80)	97Z00-00-90-5798P	A6-S20-DLS	7799-00-00-510000

OA = Available On Application  
(Millimeters in Parentheses)

# Cross Reference Guide by Machine Tool Builder

Fortune	V-Turn 26110, 2660	Main	A2-8 S30H	3.00" (76.20)	97Z00-00-90-9352P	A8-S30-DLS	7799-00-00-590000	
Fortune	V-Turn 3685	Main	A2-8 S35H	3.50" (88.90)	OA	A8-35J-DL	7799-00-00-480000	
HAAS	TL-15	Sub	A2-5 3J	1.18" (29.97)	7811-00-00-000000	A5-3J	7811-00-00-000500	
HAAS	SL-10	Main	A2-5 3J	1.75" (44.45)	7811-00-00-0000	A5-3J	7811-00-00-000500	
HAAS	HL-1, HL-2, SL-20, TL-15	Main	A2-6 S20H	2.00" (50.80)	97Z00-00-90-5798P	A6-S20-DLS	7799-00-00-510000	
HAAS	TL-15 B/B	Main	A2-6 S26H	2.50" (63.50)	97Z00-00-90-8460P	A6-S26-DLS	7799-00-00-550000	
HAAS	HL-3, HL-4, SL-20 B/B	Main	A2-6 S26H	2.56" (65.02)	97Z00-00-90-8460P	A6-S26-DLS	7799-00-00-550000	
HAAS	SL-30	Main	A2-6 S30	3.00" (76.20)	97Z00-00-90-7816N	A6-S30-DLS	7799-00-00-580000	
HAAS	HL-5, HL-6, SL-30 B/B,	Main	A2-8 F/N S40H	4.00" (101.60)	OA	A8-35J-DL	7799-00-00-480000	
HAAS	SL-40	Main	A2-8 F/N S40H	4.00" (101.60)	OA	A8-35J-DL	7799-00-00-480000	
Machine Mfr.	Machine Model	Spindle	Spindle & Collet Style	Machine Bar Capacity	PULL-BACK Style Assembly Number	Dead-Length Model Number	DEAD-LENGTH Style Assembly Number	
Hardinge	Talent 6/45	Main	A2-5 5C	1.77 (45.00)	7803-00-00-645000	OA	OA	
Hardinge	Talent 6/45	Main	A2-5 16C	1.77 (45.00)	7817-00-00-645000	OA	OA	
Hardinge	Talent 6/45	Main	A2-5 3J	1.77 (45.00)	7811-00-00-645000	OA	OA	
Hardinge	Talent 6/45	Main	A2-5 B42	1.77 (45.00)	OA	A2-5 to B42	7842-00-00-645000	
Hardinge	Talent 8/52	Main	A2-6 5C	2.05 (52.00)	7805-00-00-852000	OA	OA	
Hardinge	Talent 8/52	Main	A2-6 16C	2.05 (52.00)	7819-00-00-852000	OA	OA	
Hardinge	Talent 8/52	Main	A2-6 20C	2.05 (52.00)	7820-00-00-852000	OA	OA	
Hardinge	Talent 8/52	Main	A2-6 3J	2.05 (52.00)	7813-00-00-852200	OA	OA	
Hardinge	Talent 8/52	Main	A2-6 S20	2.05 (52.00)	7837-00-00-852200	OA	OA	
Hardinge	Talent 8/52	Main	A2-6 B60	2.05 (52.00)	OA	A2-6 to B60	7860-00-00-852000	
Hardinge	Talent 8/66	Main	A2-6 5C	2.05 (52.00)	7805-00-00-866000	OA	OA	
Hardinge	Talent 8/66	Main	A2-6 16C	2.05 (52.00)	7819-00-00-866000	OA	OA	
Hardinge	Talent 8/66	Main	A2-6 3J	2.05 (52.00)	7813-00-00-866000	OA	OA	
Hardinge	Talent 8/66	Main	A2-6 S26	2.05 (52.00)	7850-00-00-866000	OA	OA	
Hardinge	Talent 8/66	Main	A2-6 B60	2.05 (52.00)	OA	A2-6 to B60	7860-00-00-866000	
Hardinge	Talent 10/78	Main	A2-8 S30	3.07 (78.00)	7850-00-90-107800	OA	OA	
Hitachi Seiki		HTT-15S	Main	A2-5 3J	1.33" (33.78)	7811-00-00-000000	A5-3J	7811-00-00-000500
Hitachi Seiki		3NE-300	Main	A2-5 3J	1.47" (37.33)	7811-00-00-000000	A5-3J	7811-00-00-000500
Hitachi Seiki		TF-15	Main	A2-5 3J	1.50" (38.10)	7811-00-00-000000	A5-3J	7811-00-00-000500
Hitachi Seiki	HT-15	Main	A2-5 3J	1.53" (38.86)	7811-00-00-000000	A5-3J	7811-00-00-000500	
Hitachi Seiki		TS-15	Main	A2-5 3J	1.81" (45.97)	7811-00-00-000000	A5-3J	7811-00-00-000500
Hitachi Seiki		3NE	Main	A2-5 16C	1.65" (41.91)	7817-00-00-000000	A6-16C	7819-00-00-000500
Hitachi Seiki		HT-20SII	Main	A2-6 S20H	1.97" (50.03)	7837-00-00-000200	A6-S20-DLS	7799-00-00-510000
Hitachi Seiki	HT-20J, HT-20S II, HVP-20,	Main	A2-6 S20H	2.00" (50.80)	97Z00-00-90-5798P	A6-S20-DLS	7799-00-00-510000	
Hi-Cell CA-20, HTS-2793HL, HTT-20								
Hitachi Seiki	Hi-Cell 20, HT-20R, HT-20S III,	Main	A2-6 S20H	2.04" (51.81)	97Z00-00-90-5798P	A6-S20-DLS	7799-00-00-510000	
Hitachi Seiki	TF-20, Tri-Cell							
Hitachi Seiki	Hi-Cell 20	Sub	A2-6 S20H	2.04" (51.81)	97Z00-00-90-5798P	A6-S20-DLS	7799-00-00-510000	
Hitachi Seiki	Hi-Cell CA-23, HT-20S II, HT-20R III, HT-23R III	Sub	85MM-F/N	0.625" (15.87)	OA	85MM-3J-DLS	OA	
Hitachi Seiki	HTT-25, NF-20	Main	A2-8 S26H	2.12" (53.84)	97Z00-00-90-2170M	A8-S26-DLS	7799-00-00-560000	
Hitachi Seiki	4NE-600	Main	A2-8 S26H	2.16" (54.86)	97Z00-00-90-2170M	A8-S26-DLS	7799-00-00-560000	
Hitachi Seiki	Hi-Cell CA-23, -23 II, Hi-Cell HT-23R III, HTT-23S II	Main	A2-8 S26H	2.60" (66.04)	97Z00-00-90-2170M	A8-S26-DLS	7799-00-00-560000	
Hitachi Seiki	HT-20SII B/B, -25G, -D, -M, -S, -25R	Main	A2-8 S26H	2.67" (67.81)	97Z00-00-90-2170M	A6-S26-DLS	7799-00-00-550000	
Hitachi Seiki	TF-25	Main	A2-8 S26H	2.75" (69.85)	7837-00-00-000300	A8-S26-DLS	7799-00-00-560000	
Hitachi Seiki	HT-23J, HT-23S III, HVP-23	Main	A2-8 S30H	2.80" (71.12)	97Z00-00-90-9352P	A8-S30-DLS	7799-00-00-590000	
Hitachi Seiki	4NF-600	Main	A2-8 S30H	2.70" (68.58)	97Z00-00-90-9352P	A8-S30-DLS	7799-00-00-590000	
Hitachi Seiki	5NE	Main	A2-8 S30H	2.90" (73.66)	97Z00-00-90-9352P	A8-S30-DLS	7799-00-00-590000	
Hitachi Seiki	HT-30J	Main	A2-8 S30H	3.00" (76.20)	97Z00-00-90-9352P	A8-S30-DLS	7799-00-00-590000	
Hitachi Seiki	Hi-Cell CA-30, HT-30G	Main	A2-8 S30H	3.03" (76.96)	97Z00-00-90-9352P	A8-S30-DLS	7799-00-00-590000	
Hitachi Seiki	Hi-Cell CA-40, HT-40G	Main	A2-11 S40H	4.00" (101.60)	OA	A11-35J-DL	7799-00-00-490000	
Hitachi Seiki	HTT-40S	Main	A2-11 S40H	4.33" (109.98)	OA	A11-35J-DL	7799-00-00-490000	
Hwacheon	HI-ECO 2	Main	A2-5 3J	1.65" (41.91)	7811-00-00-000000	A5-3J	7811-00-00-000500	
Hwacheon	HI-ECO 15A, HI-ECO 10A, 10E, 10G	Main	A2-5 3J	1.75" (44.45)	7811-00-00-000000	A5-3J	7811-00-00-000500	
Hwacheon	HI-ECO 2, 21	Main	A2-6 3J	1.76" (44.70)	7813-00-00-000000	A6-3J	7813-00-00-000500	
Hwacheon	HI-ECO I	Main	F/N-16C	1.33" (33.78)	OA	140MM-16C-DL	7799-00-00-330000	
Hwacheon	HI-ECO 10A	Main	A2-5-16C	1.33" (33.78)	7817-00-00-000000	A5-16C	7817-00-00-000500	
Hwacheon	HI-ECO 2, 11,	Main	A2-5 16C	1.37" (34.79)	7817-00-00-000000	A5-16C	7817-00-00-000500	
Hwacheon	TTC-8	Main	A2-6 S20H	2.00" (50.80)	97Z00-00-90-5798P	A6-S20-DLS	7799-00-00-510000	
Hwacheon	HI-ECO 10B, HI-ECO 21HS	Main	A2-6 S20H	2.07" (52.57)	97Z00-00-90-5798P	A6-S20-DLS	7799-00-00-510000	
Hwacheon	HI-ECO 21HS B/B	Main	A2-6 S26H	2.55" (64.77)	97Z00-00-90-8460P	A6-S26-DLS	7799-00-00-550000	
Hwacheon	HI-ECO 2 SP3	Main	A2-8 S26H	2.75" (69.85)	97Z00-00-90-2170M	A8-S26-DLS	7799-00-00-560000	
Hwacheon	HI-ECO 25P3	Main	A2-8 S30H	2.73" (69.34)	97Z00-00-90-9352P	A8-S30-DLS	7799-00-00-590000	
Hwacheon	HI-ECO 31, 31A	Main	A2-8 S30H	2.77" (70.35)	97Z00-00-90-9352P	A8-S30-DLS	7799-00-00-590000	
Hwacheon	HI-ECO 31AA, HI-ECO 3V 2SP	Main	A2-8 S30H	3.00" (76.20)	97Z00-00-90-9352P	A8-S30-DLS	7799-00-00-590000	
Hwacheon	HI-ECO 35	Main	A2-8 S35H	3.54" (89.91)	OA	A8-35J-DL	7799-00-00-480000	
Hyundai	HT-8, 8G, 8S	Main	A2-5 3J	1.65" (41.91)	7811-00-00-000000	A5-3J	7811-00-00-000500	
Hyundai	HT-15S	Main	A2-6 S20H	2.04" (51.81)	97Z00-00-90-5798P	A6-S20-DLS	7799-00-00-510000	

OA = Available On Application (Millimeters in Parentheses)



# Cross Reference Guide by Machine Tool Builder

Hyundai	HT-18S, HT30S	Main	A2-8 S30H	2.83" (71.88)	97Z00-00-90-9352P	A8-S30-DLS	7799-00-00-590000
Hyundai	HT-20M	Main	A2-8 S30H	2.95" (74.93)	97Z00-00-90-9352P	A8-S30-DLS	7799-00-00-590000
Ikegai	TC-15, TCR-15, TU-15, TUR-15	Main	A2-6 S20H	2.04"	(51.81)	7837-00-00-000200	A6-S20-DLS
7799-00-00-510000							
Ikegai	TC-25	Main	A2-8 S26H	2.56" (65.02)	97A-0000-90-2170M	A8-S26-DLS	7799-00-00-560000
Ikegai	TC4-25H, TC-25Y, TUR-25H	Main	A2-8 S26H	2.60" (66.04)	97Z00-00-90-2170M	A8-S26-DLS	7799-00-00-560000
Ikegai	TU-26, TUR-26	Main	A2-8 S30H	3.00" (76.20)	97Z00-00-90-9352P	A8-S30-DLS	7799-00-00-590000
Ikegai	TU-30, TUR-30 B/B	Main	F/N S35H	3.62" (91.94)	OA	A8-35J-DL	7799-00-00-480000
Ikegai	TU-40	Main	A2-11 S40H	Draw Bar	OA	A11-35J-DL	7799-00-00-490000
Johnford	TC-16	Main	A2-5 3J	1.70" (43.18)	7811-00-00-000000	A5-3J	7811-00-00-000500
Johnford	TC-35 B/B	Main	F/N S35H	3.75" (95.25)	OA	A8-35J-DL	7799-00-00-480000
Johnford	TC-20-2H	Sub	A2-5 3J	1.70" (43.18)	7811-00-00-000000	A5-3J	7811-00-00-000500
Machine Mfr.	Machine Model	Spindle	Spindle & Collet Style	Machine Bar Capacity	PULL-BACK Style Assembly Number	Dead-Length Model Number	DEAD-LENGTH Style Assembly Number
Johnford	TC-20-2H	Main	A2-6 S20H	2.00" (50.80)	97Z00-00-90-5798P	A6-S20-DLS	7799-00-00-510000
Johnford	TC-35	Main	A2-8 S30H	3.00" (76.20)	97Z00-00-90-9352P	A8-S30-DLS	7799-00-00-590000
KIA	KT-15	Main	A2-5 3J	1.54" (39.11)	7811-00-00-000000	A5-3J	7811-00-00-000500
KIA	KT-30A, KT-30B	Main	A2-5 3J	1.57" (39.87)	7811-00-00-000000	A5-3J	7811-00-00-000500
KIA	KT-20	Main	A2-5 3J	1.71" (43.43)	7811-00-00-000000	A5-3J	7811-00-00-000500
KIA	KT-20S	Main	A2-6 3J	1.69" (42.92)	7813-00-00-000000	A6-3J	7813-00-00-000500
KIA	KT-21	Main	A2-6 S20H	2.05" (52.07)	7837-00-00-000200	A6-S20-DLS	7799-00-00-510000
KIA	4NE-600	Main	A2-8 S26H	2.30" (58.42)	7837-00-00-000300	A8-S26-DLS	7799-00-00-510000
KIA	KT-28, KT-31	Main	A2-8 S26H	2.62" (66.54)	7837-00-00-000300	A8-S26-DLS	7799-00-00-560000
Kitamura	MYTURN20	Main	A2-5 I6C	1.30" (33.02)	7817-00-00-000000	A5-I6C	7817-00-00-000500
Kitamura	MYTURN 10	Main	A2-5 I6C	1.43" (36.32)	7817-00-00-000000	A5-I6C	7817-00-00-000500
Kitamura	MYTURN 206	Main	A2-6 S20H	1.81" (45.97)	97Z00-00-90-5798P	A6-S20-DLS	7799-00-00-510000
Kitamura	MYTURN 20B, 30	Main	A2-6 S20H	1.85" (46.99)	97Z00-00-90-5798P	A6-S20-DLS	7799-00-00-510000
Kitamura	MYTURN 30	Main	A2-8 S26H	2.63" (66.80)	97Z00-00-90-2170M	A8-S26-DLS	7799-00-00-560000
Leadwell	LTC-1, T5	Main	A2-5 5C	1.37" (34.79)	7803-00-00-000000	A5-5C	7803-00-00-000500
Leadwell	T6	Main	A2-5 5C	2.00" (50.80)	7803-00-00-000000	A5-5C	7803-00-00-000500
Leadwell	LTC-5, T5	Main	A2-5 3J	1.37" (34.79)	7811-00-00-000000	A5-3J	7811-00-00-000500
Leadwell	T6	Main	A2-5 3J	2.00" (50.80)	7811-00-00-000000	A5-3J	7811-00-00-000500
Leadwell	T5	Main	A2-5 I6C	1.37" (34.79)	7817-00-00-000000	A5-I6C	7817-00-00-000500
Leadwell	LTC-10, LTC-15	Main	A2-5 I6C	1.61" (40.89)	7817-00-00-000000	A5-I6C	7817-00-00-000500
Leadwell	LTC-10AP	Main	A2-5 I6C	1.65" (41.91)	7817-00-00-000000	A5-I6C	7817-00-00-000500
Leadwell	T6	Main	A2-5 I6C	2.00" (50.80)	7817-00-00-000000	A5-I6C	7817-00-00-000500
Leadwell	T7	Main	A2-6 5C	2.00" (50.80)	7805-00-00-000000	A6-5C	7805-00-00-000500
Leadwell	T7	Main	A2-6 I6C	2.00" (50.80)	7819-00-00-000000	A6-I6C	7819-00-00-000500
Leadwell	T7	Main	A2-6 3J	2.00" (50.80)	7813-00-00-000000	A6-3J	7813-00-00-000500
Leadwell	T7	Main	A2-6 S20H	2.00" (50.80)	97Z00-00-90-5798P	A6-S20-DLS	7799-00-00-510000
Leadwell	GTC20, LTC-10BP, LTC-15, LTC-20AP	Main	A2-6 S20H	2.04"	(51.81)	97Z00-00-90-5798P	A6-S20-DLS
7799-00-00-510000							
Leadwell	T8, LTC-30	Main	A2-8 3J	3.00" (76.20)	7815-00-00-000000	A8-3J	7815-00-00-000500
Leadwell	T8, LTC-30	Main	A2-8 5C	3.00" (76.20)	OA	A8-5C-DL	7799-00-00-280000
Leadwell	T8, LTC-30	Main	A2-8 I6C	3.00" (76.20)	97Z00-00-90-4853M	A8-I6C	7821-00-00-000500
Leadwell	T8, LTC-30	Main	A2-8 S20H	3.00" (76.20)	97Z00-00-90-9352P	A8-S20-DLS	7799-00-00-520000
Leadwell	T8, LTC-30	Main	A2-8 S26H	3.00" (76.20)	97Z00-00-90-2170M	A8-S26-DLS	7799-00-00-560000
Leadwell	T8, LTC-30	Main	A2-8 S30H	3.00" (76.20)	97Z00-00-90-9352P	A8-S30-DLS	7799-00-00-590000
Leadwell	LTC-30A, 30B	Main	A2-8 S30H	3.07" (77.97)	97Z00-00-90-9352P	A8-S30-DLS	7799-00-00-590000
Mazak	QT-10M, -10N	Main	A2-5 3J	1.50" (38.10)	7811-00-00-000000	A5-3J	7811-00-00-000500
Mazak	QT-8, -8N, 8SP, -200, QTN-10	Main	A2-5 3J	1.61"	(40.89)	7811-00-00-000000	A5-3J
7811-00-00-000500							
Mazak	SQT-100M	Main	A2-5 3J	1.68" (42.67)	7811-00-00-000000	A5-3J	7811-00-00-000500
Mazak	SQT-10, -10MS, SQT-28S, -28MS, -30S, -30MS	Main	A2-5 3J	1.69" (42.92)	7811-00-00-000000	A5-3J	7811-00-00-000500
Mazak	Multiplex-410, -610, Nexus-100	Main	A2-5 3J	1.70"	(43.18)	7811-00-00-000000	A5-3J
7811-00-00-000500							
Mazak	Nexus-100	Main	A2-5 S20H	2.00" (50.80)	OA	A5-S20-DLS	7799-00-00-500000
Mazak	SQT-250	Sub	A2-6 3J	1.75" (44.45)	OA	A6-3J	7813-00-00-000500
Mazak	SQT-200	Sub	A2-6 S20	1.75" (44.45)	OA	A6-S26-DLS	7799-00-00-510000
Mazak	QT-10, -10N	Main	A2-6 S20H	1.81" (45.97)	97Z00-00-90-5798P	A6-S20-DLS	7799-00-00-510000
Mazak	Dual Turn-20, Integrex 200SY, SQT-15	Sub	A2-6 S20H	2.00"	(50.80)	97Z00-00-90-5798P	A6-S20-DLS
7799-00-00-510000							
Mazak	Dual Turn-20, Integrex 200Y, Nexus-200	Main	A2-6 S20H	2.00" (50.80)	97Z00-00-90-5798P	A6-S20-DLS	7799-00-00-510000
Mazak	Multiplex-415, -420, -615, -620, -6200, QT-12C, -12C BF, -15, -15N, QT-200, -200C, -250	Main	A2-6 S20H	2.00"	(50.80)	97Z00-00-90-5798P	A6-S20-DLS
7799-00-00-510000							
Mazak	QT-20, QTN-20, SQT-15, -200	Main	A2-6 S20H	2.04"	(51.81)	97Z00-00-90-5798P	A6-S20-DLS
7799-00-00-510000							
Mazak	SQT-15, SQT-200	Main	A2-6 S20H	2.83" (71.88)	7837-00-00-000200	A6-S20-DLS	7799-00-00-510000
Mazak	SQT-18, SQT-250	Sub	A2-6 S26	1.75" (44.45)	7813-00-00-000000	A6-S26-DLS	7799-00-00-550000

OA = Available On Application (Millimeters in Parentheses)

# Cross Reference Guide by Machine Tool Builder

Mazak	SQT-18	Main	A2-6 S26H	2.56" (65.02)	97Z00-00-90-8460P	A6-S26-DLS	7799-00-00-550000
Mazak	Multiplex-425, -625, Nexus-200	Main	A2-6 S26H	2.60"	(66.04)	97Z00-00-90-8460P	A6-S26-DLS
7799-00-00-550000							
Mazak	SQT-250	Main	A2-6 S26	2.63" (66.80)	97Z00-00-90-8460P	A6-S26-DLS	7799-00-00-550000
Mazak	Multiplex 6250	Main	A2-6 S26H	2.67" (67.81)	97Z00-00-90-8460P	A6-S26-DLS	7799-00-00-550000
Mazak	SQT-18, SQT-250	Main	A2-6 S26H	2.83" (71.88)	97Z00-00-90-8460P	A6-S26-DLS	7799-00-00-550000
Mazak	Multiplex-430	Main	A2-6 S30H	3.00" (76.20)	97Z00-00-90-9352P	A8-S30-DLS	7799-00-00-590000
Mazak	QT-25	Main	A2-8 S26H	2.60" (66.04)	OA	A8-S26-DLS	OA
Mazak	M-4, 4-700, QT-15	Main	A2-8 S30H	2.75" (69.85)	97Z00-00-90-9352P	A8-S30-DLS	7799-00-00-590000
Mazak	QT-20HP, -25C, -25L, -30, -30HP, -40,	Main	A2-8 S30H	2.83"	(71.88)	97Z00-00-90-9352P	A8-S30-DLS
7799-00-00-590000							
QT-250HP, -300, QTN-20HP, -30, -30HP							
Mazak	QT-18, -18N	Main	A2-8 S30H	2.86" (72.64)	97Z00-00-90-9352P	A8-S30-DLS	7799-00-00-590000
Mazak	Integrex-30, -35, -400Y, Multiplex-430, -630, Nexus-250, QT-15, -28, -28N, -30, -35, -35N, SQT-28, -28M	Main	A2-8 S30H	3.00" (76.20)	97Z00-00-90-9352P	A8-S30-DLS	7799-00-00-590000
Mazak	SQT-30	Main	A2-8 S30H	3.08" (78.23)	97Z00-00-90-9352P	A8-S30-DLS	7799-00-00-590000
Mazak	QTN-30HP B/B	Main	A2-8 S35H	2.83" (71.88)	OA	A8-35J-DL	7799-00-00-480000
<b>Machine Mfr.</b>	<b>Machine Model</b>	<b>Spindle</b>	<b>Spindle &amp; Collet Style</b>	<b>Machine Bar Capacity</b>	<b>PULL-BACK Style Assembly Number</b>	<b>Dead-Length Model Number</b>	<b>DEAD-LENGTH Style Assembly Number</b>
Mazak	QT-25, -35, -35XS, QT-300 B/B	Main	A2-8 S35H	3.50"	(88.90)	OA	A8-35J-DL
7799-00-00-480000							
Mazak	QT-30 B/B, -30HP B/B, QTN-30 B/B, -30HP B/B	Main	A2-8 S35H	3.54" (89.91)	OA	A8-35J-DL	7799-00-00-480000
Mazak	QT-28	Main	A2-8 S35H	3.55" (90.17)	OA	A8-35J-DL	7799-00-00-480000
Mazak	Nexus-350	Main	A2-11 S40H	4.00" (101.60)	OA	A11-S40-DLS	7799-00-00-620000
Mazak	Nexus 350	Main	A2-11 S50H	4.00" (101.60)	OA	A11-S50-DLS	OA
Mazak	M-5	Main	A2-11 S50H	4.70" (119.38)	OA	OA	OA
Mazak	QT-35	Main	A2-11 S50H	5.00" (127.00)	OA	OA	OA
Mazak	QT-8SP	Sub	85MM-F/N	0.59" (14.98)	OA	85MM-5C-DL	
Mazak	SQT-10MS	Sub	100MM-F/N	—	OA	100MM-3J-DLS	7799-00-00-440000
Mazak	QT6T	Main	115MM-5C	1.30 (33.02)	OA	115MM-5C-DL	OA
Mazak	QT-6G	Main	115MM-F/N	1.37" (34.79)	OA	115MM-3J-DL	OA
Methods	TMC-15	Sub	70MM-5C	N/A	OA	SPECIAL 5C-DL	OA
Methods	WT-20 II	Sub	108MM 3J	1.38" (35.05)	OA	108MM-3J-DLS	OA
Methods	TW-10	Sub	A2-5 3J	1.65" (41.91)	7811-00-00-000000	A5-3J	7811-00-00-000500
Methods	TW-10	Main	A2-5 3J	1.65" (41.91)	7811-00-00-000000	A5-3J	7811-00-00-000500
Methods	TMC-20 II	Sub	A2-5 16C	1.63" (41.40)	7817-00-00-000000	A5-16C	7817-00-00-000500
Methods	TMC-15	Main	A2-5 16C	1.38" (35.05)	7817-00-00-000000	A5-16C	7817-00-00-000500
Methods	TMC-12, -15	Main	A2-5 16C	1.63" (41.40)	7817-00-00-000000	A5-16C	7817-00-00-000500
Methods	TMC-20 II	Main	A2-5 S20H	2.04" (51.81)	OA	A5-S20-DLS	7799-00-00-500000
Methods	WT-20 II	Main	A2-5 S20H	2.75" (69.85)	OA	A5-S20-DLS	7799-00-00-500000
Methods	TW-20	Sub	A2-6 S20H	2.04" (51.81)	7837-00-00-000200	A6-S20-DLS	7799-00-00-510000
Methods	TW-20	Main	A2-6 S20H	2.04" (51.81)	97Z00-00-90-5798P	A6-S20-DLS	7799-00-00-510000
Methods	TMC-18	Main	A2-6 S20H	2.00" (50.80)	97Z00-00-90-5798P	A6-S20-DLS	7799-00-00-510000
Methods	TMC-20 II, TW-20 II	Main	A2-6 S26H	2.50" (63.50)	97Z00-00-90-8460P	A6-S26-DLS	7799-00-00-580000
Methods	WT-20 II B/B	Main	A2-6 S26H	2.75" (69.85)	97Z00-00-90-8460P	A6-S26-DLS	7799-00-00-580000
Methods	Slant 50C	Main	A2-8-S26H	2.50" (63.50)	97Z00-00-90-2170M	A8-S26-DLS	7799-00-00-560000
Methods	TW-30	Main	A2-8 S26H	2.63" (66.80)	97Z00-00-90-2170M	A8-S26-DLS	7799-00-00-560000
Methods	TW-30	Sub	A2-8 S26	2.63" (66.80)	7837-00-00-000300	A8-S26-DLS	7799-00-00-560000
Methods	SC-300, TMC-300	Main	A2-8-S30H	2.75" (69.85)	97Z00-00-90-9352P	A8-S30-DLS	7799-00-00-590000
Methods	SC-450, TMC-400	Main	A2-8-S35H	3.22" (81.78)	OA	A8-35J-DL	7799-00-00-480000
Mitsubishi	HALE-8A, MTC-8B	Main	A2-6-S20H	2.05" (52.07)	97Z00-00-90-5798P	A6-S20-DLS	7799-00-00-510000
Mitsubishi	MTC-10B	Main	A2-8-S30H	3.00" (76.20)	97Z00-00-90-9352P	A8-S26-DLS	7799-00-00-520000
Miyano	BNC-12	Main	80MM-5C	—	OA	80MM-5C-DL	OA
Miyano	BNC-20C, -20S	Main	85MM-5C	1.00" (25.40)	OA	85MM-5C-DL	OA
Miyano	LX-0, -01	Main	140MM 5C	1.06" (26.92)	OA	140MM-5C-DL	7799-00-00-300000
Miyano	BND-34T, BNE-34S	Sub	110MM-F/N	1.00" (25.40)	OA	110MM-5C-DL	7799-00-00-290000
Miyano	BNE-S2, -S3	Sub	110MM-F/N	1.00" (25.40)	OA	110MM-5C-DL	7799-00-00-290000
Miyano	BND-34S	Sub	110MM-F/N	1.02" (25.90)	OA	110MM-5C-DL	7799-00-00-290000
Miyano	BNC-34A, -34T, -42S, -42T, BND-34C, -42S, -42T	Main	110MM-F/N	1.69" (42.92)	OA	110MM-16C-DLS	7799-00-00-350000
Miyano	BNC-34C, -34S, BND-34T, BNE-34S	Main	110MM 16C	1.34"	(34.03)	OA	110MM-16C-DLS
7799-00-00-350000							
Miyano	LZ-0, -01	Main	140MM 16C	1.42" (36.06)	OA	140MM-16C-DLS	7799-00-00-330000
Miyano	LX-02, -02L, -21, -21S	Main	140MM-F/N	2.00" (50.80)	OA	140MM-S20-DLS	7799-00-00-540000
Miyano	LM-11, -21	Main	A2-5 5C	1.00" (25.40)	7803-00-00-000000	A5-5C	7803-00-00-000500
Miyano	LM-21	Main	A2-6 5C	1.00" (25.40)	OA	A6-5C	7805-00-00-000500
Miyano	6 BC	Main	A2-6 3J	1.65" (41.91)	7813-00-00-000000	A6-3J	7813-00-00-000500
Miyano	LZ092, BND-51T	Main	A2-6 S20H	2.00" (50.80)	7837-00-00-000200	A6-S20-DLS	7799-00-00-510000
Miyano	6 BC	Main	A2-6 S26H	2.24" (56.89)	97Z00-00-90-8460P	A6-S26-DLS	7799-00-00-550000
Miyano	7 BC	Main	A2-8 S30H	3.14" (79.75)	97Z00-00-90-9352P	A8-S30-DLS	7799-00-00-590000

OA = Available On Application

(Millimeters in Parentheses)

# Cross Reference Guide by Machine Tool Builder

Miyano	LE-41, -41B, -41S	Main	A2-8 S30H	3.15" (80.01)	97Z00-00-90-9352P	A8-S30-DLS	7799-00-00-590000
Miyano	LE-41, -41B, -41S	Main	A2-8 S30H	3.50" (88.90)	97Z00-00-90-9352P	A8-S30-DLS	7799-00-00-590000
Mori-Seiki	BL-05	Main	65MM-F/N	1.00" (25.40)	OA	65MM-5C-DL	OA
Mori-Seiki	CL-153, L-100H	Main	A2-5 3J	1.33" (33.78)	7811-00-00-000000	A5-3J-DLS	7811-00-00-000500
Mori-Seiki	CL-150A, DL-150	Main	A2-5 3J	1.34" (34.03)	7811-00-00-000000	A5-3J-DLS	7811-00-00-000500
Mori-Seiki	SL-150, -200	Sub	A2-5 3J	1.25" (31.75)	7811-00-00-000000	A5-3J-DLS	7811-00-00-000500
Mori-Seiki	DL-150	Main	A2-5 3J	1.80" (45.72)	7811-00-00-000000	A5-3J-DLS	7811-00-00-000500
Mori-Seiki	SL-150, -150S, -153, DL-151, ZL-150	Main	A2-5 3J	1.81" (45.97)	(45.97)	7811-00-00-000000	A5-3J-DLS
7811-00-00-000500							
Mori-Seiki	SL-200, -250A & B, -300A	Sub	A2-5 3J	—	7811-00-00-000000	A5-3J-DLS	7811-00-00-000500
Mori-Seiki	NL-1500	Main	A2-5 S20H	2.00" (50.80)	OA	A5-S20-DLS	7799-00-00-500000
Mori-Seiki	Frontier L-1	Main	A2-6 S20H	1.81" (45.97)	97Z00-00-90-5798P	A6-S20-DLS	7799-00-00-510000
Mori-Seiki	CL-200A, MT-2000SZ	Main	A2-6 S20H	2.00" (50.80)	97Z00-00-90-5798P	A6-S20-DLS	7799-00-00-510000
Mori-Seiki	SL-200MC, ZL-200	Main	A2-6 S20H	2.04" (51.81)	97Z00-00-90-5798P	A6-S20-DLS	7799-00-00-510000
Mori-Seiki	ZL-250	Main	A2-6 S26H	2.40" (69.96)	97Z00-00-90-8460P	A6-S26-DLS	7799-00-00-580000
Mori-Seiki	SL-200, -203B, 204SMC, -250, -250A	Main	A2-6 S26H	2.48" (62.99)	(62.99)	97Z00-00-90-8460P	A6-S26-DLS
7799-00-00-580000							
Mori-Seiki	CL-200B	Main	A2-6 S26H	2.50" (63.50)	97Z00-00-90-8460P	A6-S26-DLS	7799-00-00-580000
Mori-Seiki	Frontier L-2, MT-2000SZ, NL-2000, SL-203, SQR-250, -250M, ZL-200, -200SMC	Main	A2-6 S26H	2.60" (66.04)	97Z00-00-90-8460P	A6-S26-DLS	7799-00-00-580000
Mori-Seiki	MT-2500SZ	Sub	A2-6 S26H	2.60" (66.04)	OA	A6-S26-DLS	7799-00-00-580000
Mori-Seiki	SL-253A	Main	A2-8 S30H	2.76" (70.10)	97Z00-00-90-9352P	A8-S30-DLS	7799-00-00-590000
Machine Mfr.	Machine Model	Spindle	Spindle & Collet Style	Machine Bar Capacity	PULL-BACK Style Assembly Number	Dead-Length Model Number	DEAD-LENGTH Style Assembly Number
Mori-Seiki	SL-250B, -300A	Main	A2-8 S30H	2.90" (73.66)	97Z00-00-90-9352P	A8-S30-DLS	7799-00-00-590000
Mori-Seiki	MT-2500SZ, SL-2500Y, ZL-250MC, ZT-2500Y	Main	A2-8 S30H	2.95" (74.93)	97Z00-00-90-9352P	A8-S30-DLS	7799-00-00-590000
Mori-Seiki	SL-253 BMC	Main	A2-8 S30H	3.00" (76.20)	97Z00-00-90-9352P	A8-S30-DLS	7799-00-00-590000
Mori-Seiki	NL-2500	Main	A2-8 S30H	3.18" (80.97)	97Z00-00-90-9352P	A8-S30-DLS	7799-00-00-590000
Mori-Seiki	NL-3000, SL-300B	Main	A2-8 S35H	3.50" (88.90)	OA	A8-S35-DLS	OA
Mori-Seiki	SL-253B	Main	A2-8 S35H	3.54" (89.91)	OA	A8-S35-DLS	OA
Mori-Seiki	SL-400A	Main	A2-11 S40H	3.74" (94.99)	OA	A8-S35-DL	7799-00-00-480000
Nakamura	TMC-15	Sub	70MM-F/N	—	OA	70MM-5C	OA
Nakamura	WT-20 II	Sub	108MM-F/N	1.38" (35.05)	OA	108MM-3J	OA
Nakamura	TMC-15	Main	A2-5 3J	1.38" (35.05)	7817-00-00-0000	A5-3J	7811-00-00-000500
Nakamura	TW-10	Main	A2-5 3J	1.65" (41.91)	7811-00-00-0000	A5-3J	7811-00-00-000500
Nakamura	TW-10	Sub	A2-5 3J	1.65" (41.91)	OA	A5-3J	7811-00-00-000500
Nakamura	TMC-12, -15	Main	A2-5 3J	1.63" (41.40)	7817-00-00-0000	A5-3J	7811-00-00-000500
Nakamura	TMC-20 II	Sub	A2-5 3J	1.63" (41.40)	OA	A5-3J	7811-00-00-000500
Nakamura	SC-150	Sub	A2-5 3J	1.38" (35.05)	OA	A5-3J	7811-00-00-000500
Nakamura	TMC-12	Main	A2-5 16C	1.63" (41.40)	7817-00-00-0000	A5-16C-DL	7817-00-00-000500
Nakamura	SC-250, -300, TW-10, WT-250	Sub	A2-5 S20H	2.00" (50.80)	(50.80)	OA	A5-S20-DLS
7799-00-00-500000							
Nakamura	W150, WT-20 II, WTS	Main	A2-5 S20H	2.00" (50.80)	OA	A5-S20-DLS	OA
Nakamura	TMC-20 II	Main	A2-5 S20H	2.04" (51.81)	OA	A5-S20-DLS	7799-00-00-500000
Nakamura	SC-150, TMC-18	Main	A2-6 S20H	2.00" (50.80)	7837-00-00-000200	A6-S20-DLS	7799-00-00-510000
Nakamura	TW-20	Main	A2-6 S20H	2.04" (51.81)	7837-00-00-000200	A6-S20-DLS	7799-00-00-510000
Nakamura	TW-20	Sub	A2-6 S20H	2.04" (51.81)	OA	A6-S20-DLS	7799-00-00-510000
Nakamura	TMC-20 II, WT20 II B/B, WT-250	Sub	A2-6 S26H	2.50" (63.50)	(63.50)	OA	A6-S26-DLS
7799-00-00-550000							
Nakamura	SC-250, TMC-20 II	Main	A2-6 S26H	2.50" (63.50)	97Z00-00-90-8460P	A6-S26-DLS	7799-00-00-550000
Nakamura	Slant-50C	Main	A2-8 S26H	2.50" (63.50)	7837-00-00-000300	A8-S26-DLS	7799-00-00-560000
Nakamura	TW-30	Main	A2-8 S26H	2.63" (66.80)	7837-00-00-000300	A8-S26-DLS	7799-00-00-560000
Nakamura	TVV-30	Sub	A2-8 S26H	2.63" (66.80)	OA	A8-S26-DLS	7799-00-00-560000
Nakamura	SC-300, TMC-300	Main	A2-8 S30H	2.75" (69.85)	97Z00-00-90-9352P	A8-S30-DLS	7799-00-00-590000
Nakamura	SC-300	Main	A2-8 S30H	2.80" (71.12)	97Z00-00-90-9352P	A8-S30-DLS	7799-00-00-590000
Nakamura	SC-450, TMC-400	Main	A2-8 S35H	3.22" (81.78)	OA	A8-S35-DLS	OA
Nakamura	SC-450 B/B	Main	A2-8 S35H	3.50" (88.90)	OA	A8-S35-DLS	OA
Okuma	Cadet, LB-15 II, -MVV, -IIMVSub	Main	110 MM-F/N	1.10" (27.94)	OA	110MM-3J-DLS	7799-00-00-440000
Okuma	LR-10W	Main	110 MM-F/N	1.02" (25.90)	OA	110MM-5C-DL	7799-00-00-290000
Okuma	LU-15 MV	Sub	110 MM-F/N	1.00" (25.40)	OA	110MM-3J-DL	7799-00-00-440000
Okuma	Cadet	Sub	110 MM-F/N	1.10" (27.94)	OA	110MM-3J-DL	7799-00-00-440000
Okuma	Cadet-HS, ES-L6, LCS-10, VLB-200, LB-300W	Main	140MM-3J	1.69" (42.92)	OA	140MM-3J-DL	7799-00-00-420000
Okuma	LU-15 W	Sub	140 MM-F/N	1.30" (33.02)	OA	140MM-3J-DL	7799-00-00-420000
Okuma	LR-10	Main	140 MM F/N-3J	1.68" (42.67)	OA	140MM-3J-DL	7799-00-00-420000
Okuma	LT-10, LT-10M, LB-10 II, -10 IIM	Main	140 MM F/N-3J	1.73" (43.94)	(43.94)	OA	140MM-3J-DL
7799-00-00-420000							
Okuma	LB-10 II, -10 IIM	Main	140 MM F/N-3J	2.60" (66.04)	OA	140MM-3J-DL	7799-00-00-420000
Okuma	LC-10 2S B/B	Main	A2-5 16C	1.58" (40.13)	7817-00-00-000000	A5-16C-DL	7817-00-00-000500
Okuma	LC-10, -10 2ST	Main	A2-5 16C	1.25" (31.75)	7817-00-00-000000	A5-16C-DL	7817-00-00-000500
Okuma	Cadet-T	Main	A2-6 3J	1.77" (44.95)	7813-00-00-000000	A6-3J	7813-00-00-000500

OA = Available On Application

(Millimeters in Parentheses)

# Cross Reference Guide by Machine Tool Builder

Okuma	LC-20	Main	A2-6 S20H	1.81 (45.97)	97Z00-00-90-5798P	A6-S20-DLS	7799-00-00-510000	
Okuma	Cadet-C, LB-12, LC-20M	Main	A2-6 S20H	1.85 (46.99)	97Z00-00-90-5798P	A6-S20-DLS	7799-00-00-510000	
Okuma	Crown-E, ES-L8, LB-200 B/B, LB-300M, LB-300MW, LC-15, -15 2S, -15H, LCS-15H, LR-15, LT-10M B/B	Main	A2-6 S20H	2.00" (50.80)	97Z00-00-90-5798P	A6-S20-DLS	7799-00-00-510000	
Okuma	LB-15 II	Sub	A2-6 S20H	2.04" (51.81)	OA	A6-S20-DLS	7799-00-00-510000	
Okuma	LB-15 II, -15 IIM, -15 IIMV, LT-15, -15M, LU-15, -15M, -15MW, -15MY, -15W	Main	A2-6 S20H	2.04" (51.81)	97Z00-00-90-5798P	A6-S20-DLS	7799-00-00-510000	
Okuma	Crown E	Main	A2-6 S20H	2.60" (66.04)	97Z00-00-90-5798P	A6-S20-DLS	7799-00-00-510000	
Okuma	LB-15 II B/B	Main	A2-8 S26H	2.04" (51.81)	97Z00-00-90-2170M	A8-S26-DLS	7799-00-00-560000	
Okuma	LC-30	Main	A2-8 S26H	2.55" (64.77)	7837-00-00-000300	A8-S26-DLS	7799-00-00-560000	
Okuma	LC-20 B/B, -20 2ST	Main	A2-8 S26H	2.59" (65.78)	7837-00-00-000300	A8-S26-DLS	7799-00-00-560000	
Okuma	Cadet B/B, LB-15 II B/B	Main	A2-8 S26H	2.60" (66.04)	7837-00-00-000300	A8-S26-DLS	7799-00-00-560000	
Okuma	LCS-25	Main	A2-8 S26H	2.75" (69.85)	7837-00-00-000300	A8-S26-DLS	7799-00-00-560000	
Okuma	Crown B/B	Main	A2-8 S30H	2.60" (66.04)	97Z00-00-90-9352P	A6-S30-DLS	7799-00-00-580000	
Okuma	L-1420, LB-25 II, -25 IIM, LB-200S B/B, LB-300M B/B, LT-15M B/B, LU-15 B/B, -15M B/B, LU-25, -25T, LR-15 B/B, -15MR, -25, -25M	Main	A2-8 S30H	2.75" (69.85)	97Z00-00-90-9352P	A8-S30-DLS	7799-00-00-590000	
Okuma	Crown B/B	Main	A2-8 S30H	2.76" (70.10)	97Z00-00-90-9352P	A8-S30-DLS	7799-00-00-590000	
Okuma	LC-40	Main	A2-8 S30H	2.99" (75.94)	97Z00-00-90-9352P	A8-S30-DLS	7799-00-00-590000	
Okuma	LB-35 II	Main	A2-8 S30H	3.10" (78.74)	97Z00-00-90-9352P	A8-S30-DLS	7799-00-00-590000	
Okuma	LR-35M	Main	A2-8 S30H	3.15" (80.01)	97Z00-00-90-9352P	A8-S30-DLS	7799-00-00-590000	
Okuma	LU-35	Main	A2-11 S35H	3.07" (77.97)	OA	A11-35J-DL	7799-00-00-490000	
Okuma	LU-35M B/B	Main	A2-11 S35H	3.54" (39.91)	OA	A11-35J-DL	7799-00-00-490000	
<b>Machine Mfr.</b>	<b>Machine Model</b>	<b>Spindle</b>	<b>Spindle &amp; Collet Style</b>	<b>Machine Bar Capacity</b>	<b>PULL-BACK Style Assembly Number</b>	<b>Dead-Length Model Number</b>	<b>DEAD-LENGTH Style Assembly Number</b>	
Okuma	L-1420 B/B, LB-25 II B/B, LB-45 II, -45 IIM, -45 IIMY,	Main	A2-11 S35H	3.60" (91.44)	OA	A11-35J-DL	7799-00-00-490000	
Okuma	LU-35 II, -400M B/B, LR-25 B/B	Main	A2-11 S40H	3.62"	(91.94)	OA	A11-35J-DL	
7799-00-00-490000	LU-25	Main	A2-11 S40H	3.75" (95.25)	OA	A11-35J-DL	7799-00-00-490000	
Okuma	LB-45 II B/B, LC-40 B/B	Main	A2-11 S50H	4.54" (115.31)	OA	—	OA	
Okuma	Howa	ACT 25SP-15H	Main	140MM-16C	1.69"	(42.92)	OA	140MM-16C-DL
7799-00-00-330000								

OA = Available On Application

(Millimeters in Parentheses)

## Scroll-Style Collet Adaptation Chucks

### For Manual Machines

The Scroll Style Dead-Length Collet Adaptation Chuck can be mounted on any style spindle nose for lathes, grinders, rotary index tables and 4-axis tilting index tables. The F/N model number is the basic chuck onto which a base is added for the specific spindle or table applications. Please use the form on page 27 to describe your spindle.

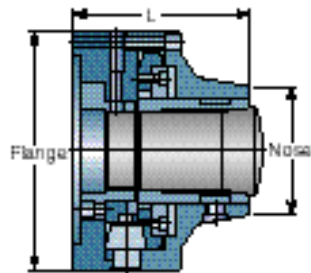
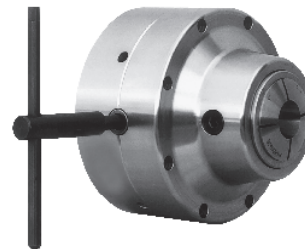

Collets sold separately.

### Dead-Length Scroll-Style Collet Adaptation Chuck

Model Number	Assembly Part Number	Spindle	OAL L	Flange OD	Nose OD	Collet Capacity
<b>5C</b>	<b>Standard 5C Collets (Precision-machined Round Collet Part Number 1001-00-19-Size)</b>					
5C-F/N-DL	7799-00-01-010000	F/N	4.221" (107.21)*	6.000" (152.40)	3.267" (82.98)	1.062" (26.97)
5C-DI-5-DL	7799-00-01-020000	DI-5 (CL)	4.221" (107.21)*	**	3.267" (82.98)	1.062" (26.97)
5C-DI-6-DL	7799-00-01-030000	DI-6 (CL)	4.221" (107.21)*	**	3.267" (82.98)	1.062" (26.97)
<b>16C</b>	<b>Standard 16C Collets (Precision-machined Round Collet Part Number 1717-00-19-Size)</b>					
16C-F/N-DL	7799-00-01-040000	F/N	5.040" (128.01)*	6.000" (152.40)	3.267" (82.98)	1.625" (41.27)
16C-DI-5-DL	7799-00-01-050000	DI-5 (CL)	5.040" (128.01)*	**	3.267" (82.98)	1.625" (41.27)
16C-DI-6-DL	7799-00-01-060000	DI-6 (CL)	5.040" (128.01)*	**	3.267" (82.98)	1.625" (41.27)
<b>3J</b>	<b>Standard 3J Collets (Precision-machined Round Collet Part Number 1593-00-19-Size)</b>					
3J-F/N-DL	7799-00-01-070000	F/N	4.475" (113.66)*	6.000" (152.40)	3.267" (82.98)	1.750" (44.45)
3J-DI-5-DL	7799-00-01-080000	DI-5 (CL)	4.475" (113.66)*	**	3.267" (82.98)	1.750" (44.45)
3J-DI-6-DL	7799-00-01-090000	DI-6 (CL)	4.475" (113.66)*	**	3.267" (82.98)	1.750" (44.45)

\* Overall Length (OAL) is for chuck assembly only. OAL may vary depending on spindle mount

\*\* Flange OD will vary with mounting plate

F/N = Flat Nose; CL = Cam Lock

(Millimeters in Parentheses)

# Sjogren Speed Collet Chucks

## For Manual Machines



### Quick to mount on all spindle configurations:

- ANSI American Standard Chucks for A1 and A2 spindles
- Taper-Key Drive Chucks for #00, #0, #1, #2 spindles
- Cam-Lock Chucks for DI-3", DI-4", DI-5", DI-6" and DI-8" spindles
- Threaded-Nose Chucks for 2¼" - 8 TPI spindles
- Plain-Back Chucks for 5", 5¾", and 6¼" plain-back spindles

Use standard 5C, 2J, 3J and 22J collets on toolroom lathes, engine lathes, and grinding machines to increase your machine capacity!

Hardinge-Sjogren Speed Collet Chucks provide greater collet capacity, reduced machining time and increased accuracy as compared to using a 3-jaw chuck. The manual chuck easily mounts to your lathe's spindle, enabling the use of precision hardened and ground collets.

The 5C Hardinge threaded or taper spindle nose versions allow the use of step chucks with closers for larger diameter secondary operation work. The 5C and 3J spindles can accept Hardinge Sure-Grip® Expanding collets which grip parts with ½" (12.70mm) to 4" (101.60mm) bores.

**Increase Capacity:** The Hardinge-Sjogren Speed Collet Chuck increases the lathe's capacity 25% to 40% compared to a lathe with a standard collet closing attachment. The Hardinge-Sjogren Speed Collet Chuck takes advantage of the full spindle bore — there is no draw tube.

**Save Time:** An almost effortless turn of the hand wheel automatically opens or closes the collet, releasing or gripping the workpiece as desired. The chuck is easily adjusted to grip a thin wall part which may be crushed with a standard collet closer.

**Use Precision-machined or Emergency Collets:** The Precision-machined collets provide an extremely long life and superior TIR as compared with a 3-jaw chuck. The emergency collet is for chucking diameters when a standard Precision-machined collet is not available.

**CAUTION:** Hardinge-Sjogren Speed Collet Chucks are designed to operate at speeds of 4,000 rpm or less. Chucks that feature a Hardinge threaded- or taper-nose spindle should not be operated in excess of 3,000 rpm when a step chuck with closer is used.

# Sjogren, 2 1/4" – 8 TPI Spindle

For Manual Machines

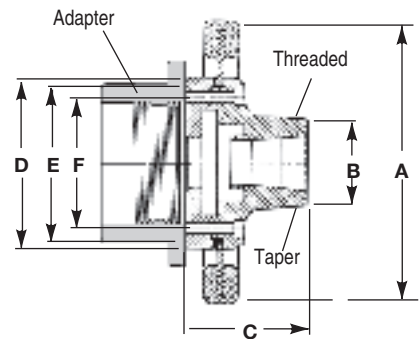

Plain nose for collet applications.  
Threaded or taper nose also accepts  
Hardinge step chucks and closers.

5CT Threaded Nose    5CX Taper Nose    5C Plain Nose

Spindle Size	Model No.	Part Number	Collet Type	Round Capacity	Dimensions						Weight lb [kg]
					A	B	C	D	E	F	
<b>2 1/4" - 8 TPI Spindle (adapter included)</b>											
2 1/4" - 8	5C	0021-00	5C	1 1/16" (26.98)	9" (228.6)	2 1/4" (57.15)	4 1/4" (107.95)	5 1/2" (139.70)	5" (127.00)	4 1/8" (104.77)	18 [8.16]
2 1/4" - 8	5CT	0011-29	5C	1 1/16" (26.98)	9" (228.6)	2 3/16" x 10 RH	4 1/4" (107.95)	5 1/2" (139.70)	5" (127.00)	4 1/8" (104.77)	22 [9.97]
2 1/4" - 8	5CX	0011-27	5C	1 1/16" (26.98)	9" (228.6)	Hardinge Taper	4 1/4" (107.95)	5 1/2" (139.70)	5" (127.00)	4 1/8" (104.77)	22 [9.97]
2 1/4" - 8	2	0022-00	2J	1 3/8" (34.92)	10" (254.00)	2 5/8" Plain	4 1/4" (107.95)	6 1/8" (155.57)	5" (127.00)	4 1/8" (104.77)	18 [8.16]

# Sjogren, American Standard (ANSI) Spindle

For Manual Machines

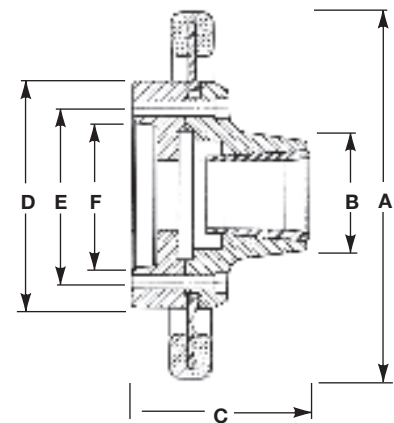

American Standard Spindle

5CT Threaded Nose    5CX Taper Nose    5C Plain Nose

Spindle Size	Model No.	Part Number	Collet Type	Round Capacity	Dimensions						Weight lb [kg]
					A	B	C	D	E	F	
<b>A2-5 Style Spindle</b>											
A1-,A2-5	5C	0057-00-00	5C	1 1/16" (26.98)	9" (228.60)	2 1/4" (57.15) Plain	4 3/4" (120.65)	5 1/2" (139.70)	4 1/8" (104.77)	3 1/4" (82.55)	16 [7.25]
A1-,A2-5	5CA <sup>1</sup>	0057-31-00	5C	1 1/16" (26.98)	7 3/4" (196.85)	2 1/4" (57.15) Plain	4 3/4" (120.65)	5 1/2" (139.70)	4 1/8" (104.77)	3 1/4" (82.55)	16 [7.25]
A1-,A2-5	5CT	0020-29-00	5C	1 1/16" (26.98)	9" (228.60)	2 3/16" x 10 RH	4 3/4" (120.65)	5 1/2" (139.70)	4 1/8" (104.77)	3 1/4" (82.55)	25 [11.33]
A1-,A2-5	5CX	0020-27-00	5C	1 1/16" (26.98)	9" (228.60)	Hardinge Taper	4 3/4" (120.65)	5 1/2" (139.70)	4 1/8" (104.77)	3 1/4" (82.55)	25 [11.33]
A1-,A2-5	2	0058-00-00	2J	1 3/8" (34.92)	10" (254.00)	2 5/8" (66.67) Plain	4 3/4" (120.65)	6 1/8" (155.57)	4 1/8" (104.77)	3 1/4" (82.55)	20 [9.07]
A1-,A2-5	2A <sup>1</sup>	0058-31-00	2J	1 3/8" (34.92)	7 3/4" (196.85)	2 5/8" (66.67) Plain	4 3/4" (120.65)	6 1/8" (155.57)	4 1/8" (104.77)	3 1/4" (82.55)	20 [9.07]
A1-,A2-5	3	0058-31-01	3J	1 3/4" (44.45)	10" (254.00)	3 1/8" (79.37) Plain	5 7/32" (148.43)	6 1/8" (155.57)	4 1/8" (104.77)	3 1/4" (82.55)	25 [11.33]
<b>A2-6 Style Spindle</b>											
A1-,A2-6	5C	0056-03-00	5C	1 1/16" (26.98)	9" (228.60)	2 1/4" (57.15) Plain	5 1/2" (139.70)	5 1/2" (139.70)	5 1/4" (133.35)	4 3/16" (106.36)	25 [11.33]
A1-,A2-6	2	0059-00-02	2J	1 3/8" (34.92)	10" (254.00)	2 5/8" (66.67) Plain	5 1/2" (139.70)	6 1/8" (155.57)	5 1/4" (133.35)	4 3/16" (106.36)	25 [11.33]
A1-,A2-6	3	0059-00-00	3J	1 3/4" (44.45)	10" (254.00)	3 1/8" (79.37) Plain	5 1/8" (130.17)	6 1/8" (155.57)	5 1/4" (133.35)	4 3/16" (106.36)	25 [11.33]
A1-,A2-6	22	0060-00-00	22J	2 1/4" (57.15)	10" (254.00)	3 5/8" (92.07) Plain	5 3/8" (136.52)	7" (177.80)	5 1/4" (133.35)	4 3/16" (106.36)	32 [14.51]
<b>A2-8 Style Spindle</b>											
A2-8	5C	0060-00-02	5C	1 1/16" (26.98)	9" (228.60)	2 1/4" (57.15) Plain	5 11/16" (144.46)	8 1/8" (206.37)	6 3/4" (171.45)	5 1/2" (139.70)	37 [17.78]
A2-8	2	0060-00-03	2J	1 3/8" (34.92)	10" (254.00)	2 5/8" (66.67) Plain	4 7/8" (123.82)	5 1/2" (139.70)	6 3/4" (171.45)	5 1/2" (139.70)	41 [18.59]
A2-8	3	0060-00-04	3J	1 3/4" (44.45)	10" (254.00)	3 1/8" (79.37) Plain	5 27/32" (148.43)	5 1/2" (139.70)	6 3/4" (171.45)	5 1/2" (139.70)	41 [18.59]
A2-8	22	0060-00-05	22J	2 1/4" (57.15)	10" (254.00)	3 5/8" (92.07) Plain	5 11/32" (135.73)	5 1/2" (139.70)	6 3/4" (171.45)	5 1/2" (139.70)	33 [14.96]

<sup>1</sup> - With 7 3/4" small handwheel – on application

NOTE: Four cap screws included with American Standard chuck.  
Adapter casting not required with 2 1/4" - 8 TPI spindle.

(Millimeters in Parentheses)  
[Kilograms in Brackets]

# Sjogren, Cam-Lock Spindle

## For Manual Machines



Cam-Lock Spindle



5CT Threaded Nose

5CX Taper Nose

5C Plain Nose

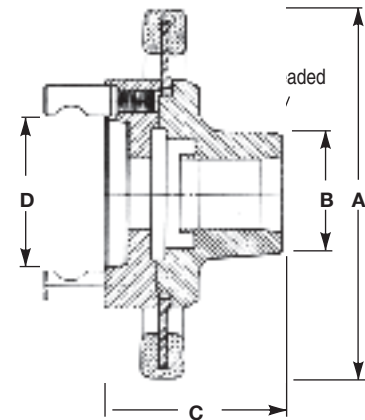

Spindle Size	Model No.	Part Number	Collet Type	Round Capacity	Dimensions				Weight lb [kg]
					A	B	C	D	
<b>DI-3" Cam-Lock Style Spindle</b>									
DI-3"	5C	0028-00-00	5C	1 1/16" (26.98)	9" (228.60)	2 1/4" (57.15) Plain	4 3/4" (120.65)	2 1/8" (53.97)	15 [6.80]
DI-3"	5CA <sup>1</sup>	0028-01-00	5C	1 1/16" (26.98)	7 3/4" (196.85)	2 1/4" (57.15) Plain	4 3/4" (120.65)	2 1/8" (53.97)	15 [6.80]
DI-3"	5CT	0013-29-00	5C	1 1/16" (26.98)	9" (228.60)	2 3/16" x 10 RH	4 3/4" (120.65)	2 1/8" (53.97)	18 [8.16]
DI-3"	5CAT <sup>1</sup>	0013-30-00	5C	1 1/16" (26.98)	7 3/4" (196.85)	2 3/16" x 10 RH	4 3/4" (120.65)	2 1/8" (53.97)	18 [8.16]
DI-3"	5CX	0013-27-00	5C	1 1/16" (26.98)	9" (228.60)	Hardinge Taper	4 3/4" (120.65)	2 1/8" (53.97)	18 [8.16]
DI-3"	5CAX <sup>1</sup>	0013-28-00	5C	1 1/16" (26.98)	7 3/4" (196.85)	Hardinge Taper	4 3/4" (120.65)	2 1/8" (53.97)	18 [8.16]
DI-3"	2	0030-90-00	2j	1 3/8" (34.92)	10" (254.00)	2 5/8" (66.67) Plain	4 3/4" (120.65)	2 1/8" (53.97)	15 [6.80]
DI-3"	2A <sup>1</sup>	0029-00-00	2j	1 3/8" (34.92)	7 3/4" (196.85)	2 5/8" (66.67) Plain	4 3/4" (120.65)	2 1/8" (53.97)	15 [6.80]
DI-3"	3	0029-00-01	3j	1 3/4" (44.45)	10" (254.00)	3 1/8" (79.37) Plain	5" (127.00)	2 1/8" (53.97)	20 [9.07]
<b>DI-4" Cam-Lock Style Spindle</b>									
DI-4"	5C	0030-00-00	5C	1 1/16" (26.98)	9" (228.60)	2 1/4" (57.15) Plain	4 3/4" (120.65)	2 1/2" (63.50)	15 [6.80]
DI-4"	5CA <sup>1</sup>	0030-31-00	5C	1 1/16" (26.98)	7 3/4" (196.85)	2 1/4" (57.15) Plain	4 3/4" (120.65)	2 1/2" (63.50)	15 [6.80]
DI-4"	5CAT <sup>1</sup>	0014-30-00	5C	1 1/16" (26.98)	7 3/4" (196.85)	Hardinge Taper	4 3/4" (120.65)	2 1/2" (63.50)	18 [8.16]
DI-4"	5CX	0014-27-00	5C	1 1/16" (26.98)	9" (228.60)	Hardinge Taper	4 3/4" (120.65)	2 1/2" (63.50)	18 [8.16]
DI-4"	2	0031-00-00	2j	1 3/8" (34.92)	10" (254.00)	2 5/8" (66.67) Plain	4 3/4" (120.65)	2 1/2" (63.50)	15 [6.80]
DI-4"	2A <sup>1</sup>	0031-31-00	2j	1 3/8" (34.92)	7 3/4" (196.85)	2 5/8" (66.67) Plain	4 3/4" (120.65)	2 1/2" (63.50)	15 [6.80]
DI-4"	3	0032-00-00	3j	1 3/4" (44.45)	10" (254.00)	3 1/8" (79.37) Plain	5 1/8" (130.17)	2 1/2" (63.50)	23 [10.43]
<b>DI-5" Cam-Lock Style Spindle</b>									
DI-5"	5C	0033-00-00	5C	1 1/16" (26.98)	9" (228.60)	2 1/4" (57.15) Plain	4 3/4" (120.65)	3 1/4" (82.55)	15 [6.80]
DI-5"	5CA <sup>1</sup>	0033-31-00	5C	1 1/16" (26.98)	7 3/4" (196.85)	2 1/4" (57.15) Plain	4 3/4" (120.65)	3 1/4" (82.55)	15 [6.80]
DI-5"	5CT	0015-29-00	5C	1 1/16" (26.98)	9" (228.60)	2 3/16" x 10 RH	4 3/4" (120.65)	3 1/4" (82.55)	18 [8.16]
DI-5"	5CX	0015-27-00	5C	1 1/16" (26.98)	9" (228.60)	Hardinge Taper	4 3/4" (120.65)	3 1/4" (82.55)	18 [8.16]
DI-5"	2	0034-00-00	2j	1 3/8" (34.92)	10" (254.00)	2 5/8" (66.67) Plain	4 3/4" (120.65)	3 1/4" (82.55)	15 [6.80]
DI-5"	2A <sup>1</sup>	0034-31-00	2j	1 3/8" (34.92)	7 3/4" (196.85)	2 5/8" (66.67) Plain	4 3/4" (120.65)	3 1/4" (82.55)	15 [6.80]
DI-5"	3	0035-00-00	3j	1 3/8" (34.92)	10" (254.00)	3 1/8" (79.37) Plain	5 1/8" (130.17)	3 1/4" (82.55)	23 [10.43]
DI-5"	22	0036-00-00	22j	2 1/4" (57.15)	10" (254.00)	3 5/8" (92.07) Plain	5 1/2" (139.70)	3 1/4" (82.55)	28 [12.70]
<b>DI-6" Cam-Lock Style Spindle</b>									
DI-6"	5C	0037-00-00	5C	1 1/16" (26.98)	9" (228.60)	2 1/4" (57.15) Plain	4 7/8" (123.82)	4 3/16" (106.36)	17 [7.71]
DI-6"	5CT	0016-29-00	5C	1 1/16" (26.98)	9" (228.60)	2 3/16" x 10 RH	4 7/8" (123.82)	4 3/16" (106.36)	20 [9.07]
DI-6"	5CX	0016-27-00	5C	1 1/16" (26.98)	9" (228.60)	Hardinge Taper	4 7/8" (123.82)	4 3/16" (106.36)	20 [9.07]
DI-6"	2	0038-00-00	2j	1 3/8" (34.92)	10" (254.00)	2 5/8" (66.67) Plain	4 7/8" (123.82)	4 3/16" (106.36)	17 [7.71]
DI-6"	3	0039-00-00	3j	1 3/4" (44.45)	10" (254.00)	3 1/8" (79.37) Plain	5 1/4" (133.35)	4 3/16" (106.36)	24 [10.88]
DI-6"	22	0040-00-00	22j	2 1/4" (57.15)	10" (254.00)	3 5/8" (92.07) Plain	5 3/8" (136.52)	4 3/16" (106.36)	29 [13.15]
<b>DI-8" Cam-Lock Style Spindle</b>									
DI-8"	5C	0037-01-00	5C	1 1/16" (26.98)	9" (228.60)	2 1/4" (57.15) Plain	4 7/8" (123.82)	5 1/2" (139.70)	17 [7.71]
DI-8"	2	0041-00-00	2j	1 3/8" (34.92)	10" (254.00)	2 5/8" (66.67) Plain	5" (127.00)	5 1/2" (139.70)	23 [10.43]
DI-8"	3	0042-00-00	3j	1 3/4" (44.45)	10" (254.00)	3 1/8" (79.37) Plain	5 3/8" (136.52)	5 1/2" (139.70)	26 [11.79]
DI-8"	22	0043-00-00	22j	2 1/4" (57.15)	10" (254.00)	3 5/8" (92.07) Plain	5 1/2" (139.70)	5 1/2" (139.70)	33 [14.96]

<sup>1</sup> - With 7 3/4" small handwheel – on application

(Millimeters in Parentheses)  
[Kilograms in Brackets]

# Sjogren, Plain-back Style

## For Manual Machines

Adapters are required to mount plain-back chucks to a spindle. Refer to information at bottom of page.



5CT Threaded Nose    5CX Taper Nose    5C Plain Nose

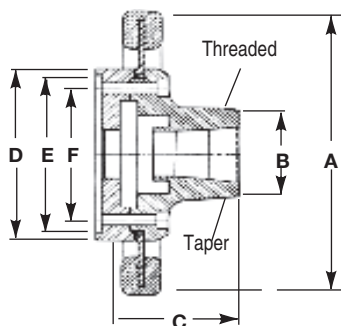

Threaded or taper nose also accepts Hardinge step chucks and closers

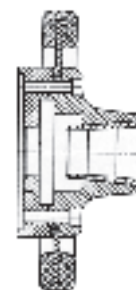

Plain nose for collet applications

Chuck Number	Part Number	Collet Used	Round Capacity	Dimensions						Weight lb [kg]	
				A	B	C	D	E	F		
<b>Plain Back Chuck - 5C Spindle Nose (5" Chuck: E-Dimension)</b>											
5C	0023-00-00	5C	1 1/16" (26.98)	9" (228.60)	2 1/4" (57.15)	Plain	4 1/4" (107.95)	5 1/2" (139.70)	5" (127.00)	4 1/8" (104.77)	15 [6.80]
5CA	0023-31-00 <sup>1</sup>	5C	1 1/16" (26.98)	7 3/4" (196.85)	2 1/4" (57.15)	Plain	4 1/4" (107.95)	5 1/2" (139.70)	5" (127.00)	4 1/8" (104.77)	15 [6.80]
5CT	0012-29-00	5C	1 1/16" (26.98)	9" (228.60)	2 3/16" x 10 RH		4 1/4" (107.95)	5 1/2" (139.70)	5" (127.00)	4 1/8" (104.77)	17 [7.71]
5CAT	0012-30-00 <sup>1</sup>	5C	1 1/16" (26.98)	7 3/4" (196.85)	2 3/16" x 10 RH		4 1/4" (107.95)	5 1/2" (139.70)	5" (127.00)	4 1/8" (104.77)	17 [7.71]
5CX	0012-27-00	5C	1 1/16" (26.98)	9" (228.60)	Hardinge Taper		4 1/4" (107.95)	5 1/2" (139.70)	5" (127.00)	4 1/8" (104.77)	17 [7.71]
5CAX	0012-28-00 <sup>1</sup>	5C	1 1/16" (26.98)	7 3/4" (196.85)	Hardinge Taper		4 1/4" (107.95)	5 1/2" (139.70)	5" (127.00)	4 1/8" (104.77)	17 [7.71]
<b>Plain Back Chuck - 2J and 3J Spindle Nose (5 3/4" Chuck: E-Dimension)</b>											
2	0024-00-00	2J	1 3/8" (34.92)	10" (254.00)	2 5/8" (66.67)	Plain	4 1/4" (107.95)	6 1/8" (155.57)	5 3/4" (155.57)	4 5/8" (117.47)	19 [8.61]
2A	0024-31-00 <sup>1</sup>	2J	1 3/8" (34.92)	7 3/4" (196.85)	2 5/8" (66.67)	Plain	4 1/4" (107.95)	6 1/8" (155.57)	5 3/4" (155.57)	4 5/8" (117.47)	19 [8.61]
3	0025-00-00	3J	1 3/4" (44.45)	10" (254.00)	3 1/8" (79.37)	Plain	4 5/8" (117.47)	6 1/2" (165.10)	5 3/4" (155.57)	5 1/4" (133.35)	23 [10.43]
<b>Plain Back Chuck - 22J Spindle Nose (6 1/4" Chuck: E-Dimension)</b>											
22	0026-00-00	22J	2 1/4" (57.15)	10" (254.00)	3 5/8" (92.07)	Plain	4 7/8" (123.82)	7" (177.80)	6 1/4" (158.75)	5 1/4" (133.35)	28 [12.70]

<sup>1</sup> - With 7 3/4" small handwheel - on application

NOTE: Four hollow-head cap screws included with plain-back chuck.

(Millimeters in Parentheses)  
[Kilograms in Brackets]

## Adapter Casting for Plain-Back Style

Adapters are required to mount plain back chucks to the machine's spindle. The adapter casting is to be machined by the customer using the following dimensions.

Chuck Number	Dimensions				
	A	B	C	D	E
5C	3 3/4" (95.25)	2 1/4" (57.15)	5 1/4" (133.35)	1 1/8" (28.57)	3/4" (19.05)
2	4 1/4" (107.95)	2 1/2" (63.50)	6" (152.40)	1 1/2" (38.10)	3/4" (19.05)
3	4 1/4" (107.95)	2 1/2" (63.50)	6" (152.40)	1 1/2" (38.10)	3/4" (19.05)
22	4 1/2" (107.95)	3" (76.20)	6 1/2" (165.10)	1 3/4" (44.45)	1" (25.40)

(Millimeters in Parentheses)

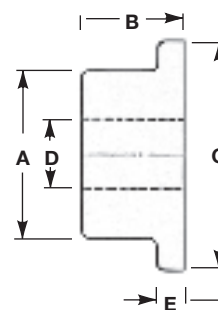



# Sjogren, Taper-Key Style

## For Manual Machines



Taper-Key Spindle



5CT Threaded Nose    5CX Taper Nose    5C Plain Nose

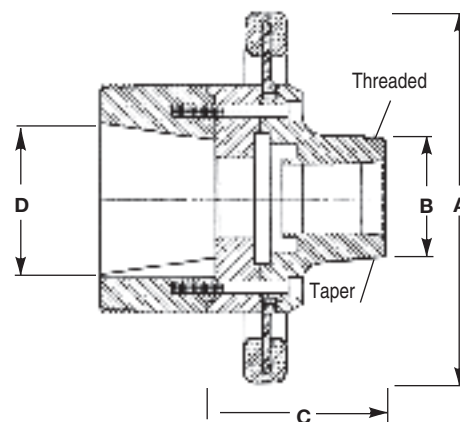

Spindle Size	Model No.	Part Number	Collet Type	Round Capacity	Dimensions				Weight lb [kg]
					A	B	C	D	
<b>#00 Taper Key-Mount Style Spindle</b>									
#00 (L-00)	5C	0044-00-00	5C	1 1/16" (26.98)	9" (228.60)	2 1/4" (57.15) Plain	4 1/4" (107.95)	2 3/4" (69.85)	23 [10.42]
#00 (L-00)	5CA <sup>1</sup>	0044-31-00	5C	1 1/16" (26.98)	7 3/4" (196.85)	2 1/4" (57.15) Plain	4 1/4" (107.95)	2 3/4" (69.85)	23 [10.42]
#00 (L-00)	5CT	0017-29-00	5C	1 1/16" (26.98)	9" (228.60)	2 3/16" x 10 RH	4 1/4" (107.95)	2 3/4" (69.85)	25 [11.33]
#00 (L-00)	5CX	0017-27-00	5C	1 1/16" (26.98)	9" (228.60)	Hardinge Taper	4 1/4" (107.95)	2 3/4" (69.85)	25 [11.33]
#00 (L-00)	2	0045-00-00	2J	1 3/8" (34.92)	10" (254.00)	2 5/8" (66.67) Plain	4 1/4" (107.95)	2 3/4" (69.85)	24 [10.88]
#00 (L-00)	2A <sup>1</sup>	0045-31-00	2J	1 3/8" (34.92)	7 3/4" (196.85)	2 5/8" (66.67) Plain	4 1/4" (107.95)	2 3/4" (69.85)	24 [10.88]
#00 (L-00)	3	0046-00-00	3J	1 3/4" (44.45)	10" (254.00)	3 1/8" (79.37) Plain	4 5/8" (117.47)	2 3/4" (69.85)	28 [12.70]
<b>#0 Taper Key-Mount Style Spindle</b>									
#0 (L-0)	5C	0047-00-00	5C	1 1/16" (26.98)	9" (228.60)	2 1/4" (57.15) Plain	4 1/4" (107.95)	3 1/4" (82.55)	25 [11.33]
#0 (L-0)	5CA <sup>1</sup>	0047-31-00	5C	1 1/16" (26.98)	7 3/4" (196.85)	2 1/4" (57.15) Plain	4 1/4" (107.95)	3 1/4" (82.55)	25 [11.33]
#0 (L-0)	5CT	0018-29-00	5C	1 1/16" (26.98)	9" (228.60)	2 3/16" x 10 RH	4 1/4" (107.95)	3 1/4" (82.55)	27 [12.24]
#0 (L-0)	5CX	0018-27-00	5C	1 1/16" (26.98)	9" (228.60)	Hardinge Taper	4 1/4" (107.95)	3 1/4" (82.55)	27 [12.24]
#0 (L-0)	2	0048-00-00	2J	1 3/8" (34.92)	10" (254.00)	2 5/8" (66.67) Plain	4 1/4" (107.95)	3 1/4" (82.55)	26 [11.79]
#0 (L-0)	2A <sup>1</sup>	0048-31-00	2J	1 3/8" (34.92)	7 3/4" (196.85)	2 5/8" (66.67) Plain	4 1/4" (107.95)	3 1/4" (82.55)	26 [11.79]
#0 (L-0)	3	0049-00-00	3J	1 3/4" (44.45)	10" (254.00)	3 1/8" (79.37) Plain	4 5/8" (117.47)	3 1/4" (82.55)	32 [14.51]
<b>#1 Taper Key-Mount Style Spindle</b>									
#1 (L-1)	5C	0050-00-00	5C	1 1/16" (26.98)	9" (228.60)	2 1/4" (57.15) Plain	4 1/4" (107.95)	4 1/8" (107.77)	26 [11.79]
#1 (L-1)	5CA <sup>1</sup>	0050-31-00	5C	1 1/16" (26.98)	7 3/4" (196.85)	2 1/4" (57.15) Plain	4 1/4" (107.95)	4 1/8" (107.77)	26 [11.79]
#1 (L-1)	5CT	0019-29-00	5C	1 1/16" (26.98)	9" (228.60)	2 3/16" x 10 RH	4 1/4" (107.95)	4 1/8" (107.77)	28 [12.70]
#1 (L-1)	5CX	0019-27-00	5C	1 1/16" (26.98)	9" (228.60)	Hardinge Taper	4 1/4" (107.95)	4 1/8" (107.77)	28 [12.70]
#1 (L-1)	2	0051-00-00	2J	1 3/8" (34.92)	10" (254.00)	2 5/8" (66.67) Plain	4 1/4" (107.95)	4 1/8" (107.77)	27 [12.24]
#1 (L-1)	3	0052-00-00	3J	1 3/4" (44.45)	10" (254.00)	3 1/8" (79.37) Plain	4 5/8" (117.47)	4 1/8" (107.77)	35 [15.87]
#1 (L-1)	22	0053-00-00	22J	2 1/4" (57.15)	10" (254.00)	3 5/8" (92.07) Plain	4 7/8" (123.82)	4 1/8" (107.77)	40 [18.14]
<b>#2 Taper Key-Mount Style Spindle</b>									
#2 (L-2)	5C	0053-00-02	5C	1 1/16" (26.98)	9" (228.60)	2 1/4" (57.15) Plain	4 1/4" (107.95)	5 1/4" (133.35)	34 [15.42]
#2 (L-2)	2	0054-00-00	2J	1 3/8" (34.92)	10" (254.00)	2 5/8" (66.67) Plain	4 1/4" (107.95)	5 1/4" (133.35)	35 [15.87]
#2 (L-2)	3	0055-00-00	3J	1 3/4" (44.45)	10" (254.00)	3 1/8" (79.37) Plain	4 5/8" (117.47)	5 1/4" (133.35)	41 [18.59]
#2 (L-2)	22	0056-00-00	22J	2 1/4" (57.15)	10" (254.00)	3 5/8" (92.07) Plain	4 7/8" (123.82)	5 1/4" (133.35)	46 [20.86]

<sup>1</sup> - With 7 3/4" small handwheel – on application

(Millimeters in Parentheses)  
[Kilograms in Brackets]

FlexC QUICK CHANGE COLLET CHUCKS

# WHY BUY A FLEXC QUICK-CHANGE COLLET SYSTEM?

- 10x THE GRIP RANGE OF STANDARD COLLETS +/- .020"  
100MM COLLETS +/- .040"
- 2x AS ACCURATE (.0004 TIR)  
TRUE PARALLEL GRIPPING
- UP TO 19x FASTER CHANGEOVER COMPARED TO STANDARD COLLETS OR 3 JAW CHUCKS
- LIFETIME GUARANTEE ON COLLET VULCANIZATION
- FULLY INTERCHANGEABLE WITH COMPETITOR MODELS (42, 65, 80 & 100mm)



AMERICAN MADE  
★ WORKHOLDING

## FLEXC DESIGN UPGRADES

### ULTIMATE FLEXIBILITY

Capable of accepting Hardinge Quick Change Adapters.

### COMPACT DESIGN

Compact design allows for optimal tool clearances and maximum machining workspace.

### BETTER PART FINISH

Collet chucks allow for higher RPMs than traditional 3-jaw chucks.

### QUALITY ASSURANCE

Manufactured and assembled in the USA with top grade materials and inspection processes.

### ACCURACY IMPROVEMENTS

.0002" TIR on the closing angle of the chuck.

### 10x THE GRIP RANGE

Grip range of +/- .020" allowing for part size variation. 42, 65, 80, +/- .040" on 100mm collets

# Drawbar Linkup Order Form

## Request for Machine Spindle and Drawbar Information

Drawbar Linkups are required for mounting Hardinge Chucks and Collet Adaptation Chucks including the FlexC™ Collet System to CNC lathes. Fill in the requested information and dimensions corresponding to the illustration if you would like Hardinge to machine the drawbar linkup for your specific application. You may contact Hardinge for a preliminary quote prior to filling out this form at 800-843-8801.

Company \_\_\_\_\_

Contact Name \_\_\_\_\_

Address \_\_\_\_\_

City, State, Zip \_\_\_\_\_

Phone \_\_\_\_\_ Fax \_\_\_\_\_

Machine Manufacturer \_\_\_\_\_ Machine Model \_\_\_\_\_

Actuator Manufacturer \_\_\_\_\_

Chuck, Collet Chuck or FlexC™ System Part Number \_\_\_\_\_

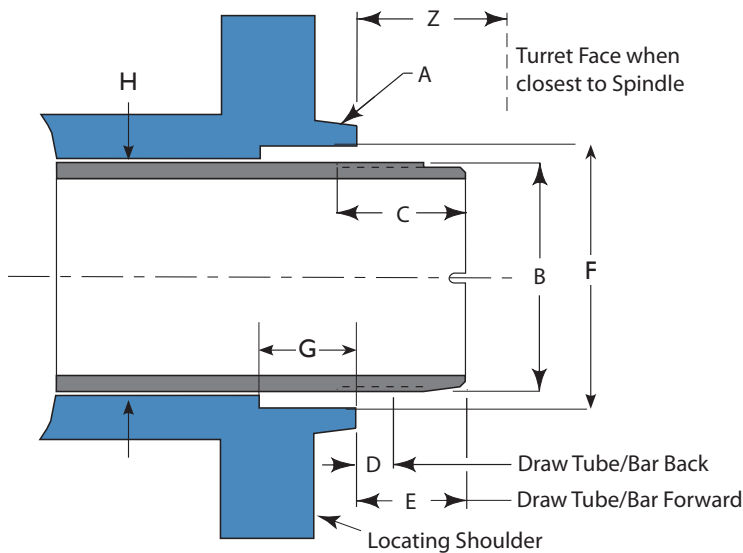

A. Spindle Configuration  A2-5  A2-6  A2-8  
or other \_\_\_\_\_

B. Draw Tube / Bar Thread \_\_\_\_\_

Left-hand or  Right-hand

Internal or  External Thread

C. Length of Thread \_\_\_\_\_

D/E. Distance from Front of Spindle to Front of Draw Tube / Bar when Forward and Retracted.

(Indicate positive {+} if the draw tube / bar is in front of the spindle face, or negative {-} if behind the spindle face)

D. Retracted (back) \_\_\_\_\_

E. Forward \_\_\_\_\_

F. Spindle I.D. Step Diameter or Tapers (if any): \_\_\_\_\_

G. Depth of Steps \_\_\_\_\_

H. Spindle Through Hole \_\_\_\_\_

Z. Turret Face when closest to Spindle \_\_\_\_\_

**Email this form to [orders@hardinge.com](mailto:orders@hardinge.com) or fax to Hardinge Customer Service at 607.734.3886**  
[www.shophardinge.com](http://www.shophardinge.com) phone: 800.843.8801

# Forkardt Hardinge, a solution for every industry

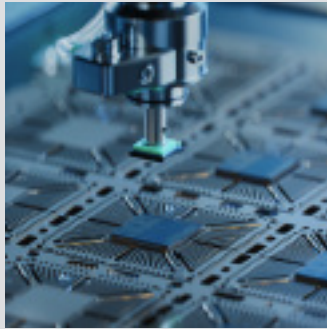

833-791-9681  
FORKARDTHARDINGE.COM  
SALES@FORKARDTHARDINGE.COM

All prices & specifications are subject to change without notice.  
All marks indicated by ® and TM are trademarks of their respective owners.  
#2352\_Collet Adaptation Chuck in USA © Forkardt Hardinge 2025 • 01/25